

Supplement

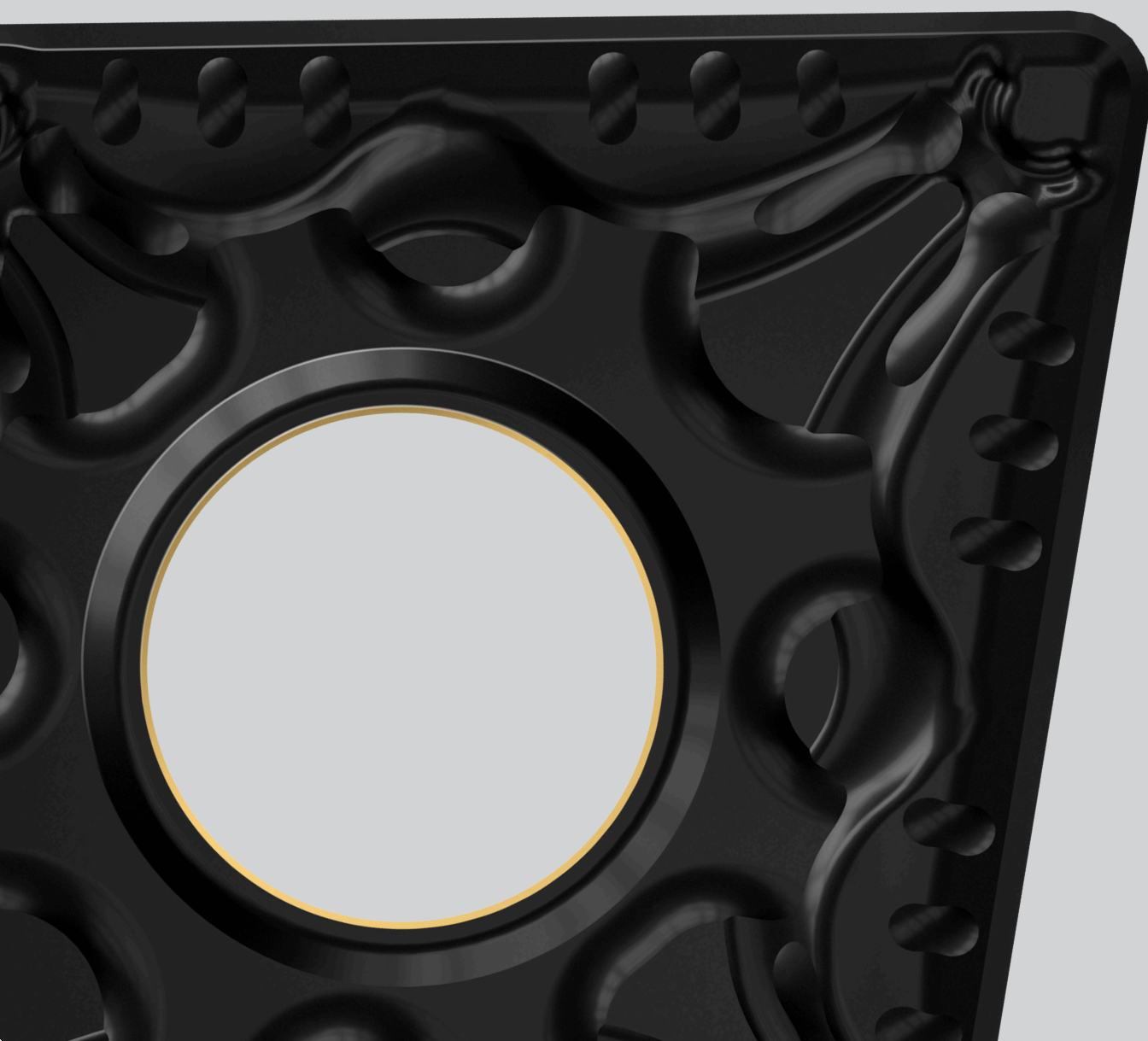

General turning	A
Parting and grooving	B
Milling	C
Drilling	D
Tool holding	E
Rotating tool adaptors	F
General information	G

General turning

CoroTurn® Prime

Inserts 3

CoroTurn® 300

Inserts 4

CoroTurn® 107

Inserts 5-10

T-Max® P

Inserts 11-22
External tools 23-25

T-Max®

Inserts 26-27

CoroTurn® 111

Inserts 28-31

T-Max® S

Inserts 32-33

For complete assortment, see www.sandvik.coromant.com

CoroTurn® Prime insert for turning

B-type insert

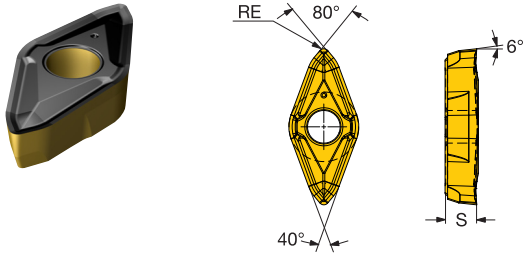

		SSC	S	RE	ISO CODE	S
Medium	H3	CP-	5.00	0.8	CP-B1108-H3	★

SSC = To correspond with SSC on holder.



CoroTurn® 300 insert for turning

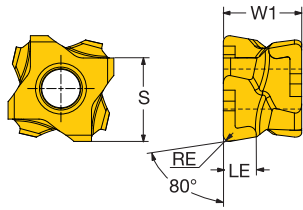

B

		SSC	LE	S	RE	W1	BS	ISO CODE	P		K	
									4415	4425	4415	4425
Finishing	L4	10	4.0	11.00	0.4	10.0		3-80-101104-8-L4	★	☆	★	☆
		4.0	11.00	0.8	10.0		3-80-101108-8-L4	★	☆	★	☆	
		4.0	11.00	1.2	10.0		3-80-101112-8-L4	★	☆	★	☆	
Medium	M5	10	4.0	11.00	0.8	10.0		3-80-101108-8-M5	☆	★	☆	★
		4.0	11.00	1.2	10.0		3-80-101112-8-M5	☆	★	☆	★	
	M5W	10	4.0	11.00	0.8	10.0	0.7	3-80-101108-8-M5W	☆	★	☆	★
		4.0	11.00	1.2	10.0	0.8	3-80-101112-8-M5W	☆	★	☆	★	

C

SSC = To correspond with SSC on holder.

D

E

CoroTurn® 107 insert for turning

C-style insert (Rhombic 80°)

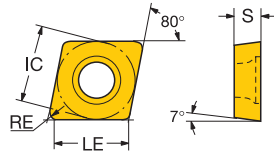
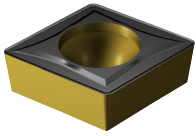

		LE	S	RE	ISO CODE	P		K		S		
						4415	4425	4415	4425	S2	S5	
Finishing	MF	09	8.9	3.97	0.7	CCMT 09 T3 08-MF					*	
Medium	PMC	09	9.3	3.97	0.4	CCMT 09 T3 04-PMC		*		*		
			8.9	3.97	0.7	CCMT 09 T3 08-PMC		*		*		
	UM	06	5.6	2.38	0.7	CCMT 06 02 08-UM	*		*			
Roughing	UR	06	6.0	2.38	0.4	CCMT 06 02 04-UR	*		*			

B

C

D

E



CoroTurn® 107 insert for turning

D-style insert (Rhombic 55°)

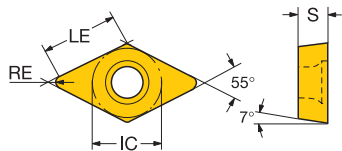
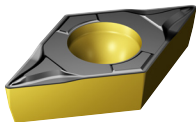

B

						P	K	S	
			LE	S	RE	ISO CODE			
Finishing	MF	11	10.8	3.97	0.8	4425	4425	52/05	
		DCMT 11 T3 08-MF							*
Medium	PMC	11	11.2	3.97	0.4	*	*		
		10.8	3.97	0.8		*	*		
		DCMT 11 T3 04-PMC							
DCMT 11 T3 08-PMC									

C

D

E



CoroTurn® 107 insert for turning

R-style insert (Round)

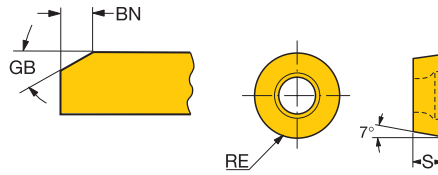
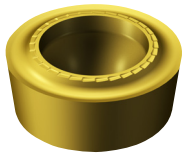

		S	RE	GB	BN	ISO CODE	P		K		S		
							4415	4425	4415	4425	S205		
Finishing	L3	08	3.18	4.0		RCMT 08 03 MP-L3						★	
		10	3.97	5.0		RCMT 10 T3 MP-L3						★	
		12	4.76	6.0		RCMT 12 04 MP-L3						★	
		16	6.35	8.0		RCMT 16 06 MP-L3						★	
Medium	M3	08	3.18	4.0		RCMT 08 03 MP-M3						★	
		10	3.97	5.0		RCMT 10 T3 MP-M3						★	
		12	4.76	6.0		RCMT 12 04 MP-M3						★	
		16	6.35	8.0		RCMT 16 06 MP-M3						★	
	M0	05	2.38	2.5	0°	0.10	RCMT 05 02 M0	★	★	★	★		
		06	2.38	3.0	0°	0.10	RCMT 06 02 M0	☆	★	☆	★		
		08	3.18	4.0	0°	0.10	RCMT 08 03 M0	☆	★	☆	★		
		10	3.97	5.0	15°	0.10	RCMT 10 T3 M0	☆	★	☆	★		
		12	4.76	6.0	15°	0.12	RCMT 12 04 M0	☆	★	☆	★		
		16	6.35	8.0	15°	0.15	RCMT 16 06 M0	☆	★	☆	★		
		20	6.35	10.0	15°	0.15	RCMT 20 06 M0		★		★		
		25	7.94	12.5	15°	0.20	RCMT 25 07 M0		★		★		
	32	9.53	16.0	15°	0.20	RCMT 32 09 M0		★		★			
	SM	06	3.18	3.2			RCMT 06 03 00-SM						★
		08	3.18	4.0			RCMT 08 03 M0-SM						★
		09	3.97	4.8	15°	0.10	RCMT 09 T3 00-SM						★
		10	3.97	5.0	15°	0.10	RCMT 10 T3 M0-SM						★
		12	4.76	6.0	15°	0.10	RCMT 12 04 M0-SM						★
			4.76	6.4	15°	0.10	RCMT 12 04 00-SM						★
		16	6.35	8.0	15°	0.10	RCMT 16 06 M0-SM						★
00	06	3.18	3.2	0°	0.10	RCMT 06 03 00	☆	★	☆	★			
	09	3.97	4.8	15°	0.08	RCMT 09 T3 00	☆	★	☆	★			
	12	4.76	6.4	15°	0.12	RCMT 12 04 00	☆	★	☆	★			
	19	6.35	9.5	15°	0.15	RCMT 19 06 00		★		★			
	09	3.97	4.8	15°	0.10	RCMT 09 T3 00-M0		★		★			
	12	4.76	6.4	15°	0.12	RCMT 12 04 00-M0	☆	★	☆	★			
Roughing	H7	08	3.18	4.0		RCMT 08 03 MP-H7						★	
		10	3.97	5.0		RCMT 10 T3 MP-H7						★	
		12	4.76	6.0		RCMT 12 04 MP-H7						★	
		16	6.35	8.0		RCMT 16 06 MP-H7						★	

B

C

D

E



CoroTurn® 107 insert for turning

S-style insert (Square)

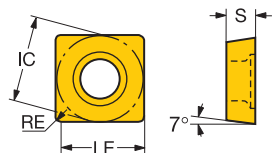

B

		LE	S	RE	ISO CODE	P		K	
		09	9.1	3.97	0.4	4415	4425	4415	4425
Medium	PMC				SCMT 09 T3 04-PMC	*	*	*	*
Roughing	UR	12	11.9	4.76	0.8	SCMT 12 04 08-UR	*	*	
	XL	38	38.0	9.53	3.2	SCMT 38 09 32-XL	*	*	*
	XH	38	34.9	12.70	3.2	SBMT 38 12 32-XH	*	*	*

C

D

E



CoroTurn® 107 insert for turning

T-style insert (Triangular)

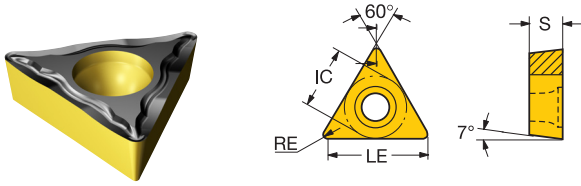

					ISO CODE	P	K	
		LE	S	RE		4415	4415	
Medium	UM	09	8.6	2.38	0.8	TCMT 09 02 08-UM	★	★

CoroTurn® 107 insert for turning

V-style insert (Rhombic 35°)

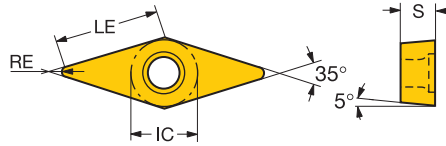
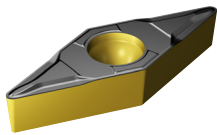

		LE	S	RE	ISO CODE	P		K		S
		16	15.8	4.76	0.8	4415	4425	4415	4425	S205
Finishing	MF	16	15.8	4.76	0.8	VBMT 16 04 08-MF				*
	UF	11	10.3	2.38	0.8	VBMT 11 02 08-UF	*	*		
Medium	PMC	16	16.2	4.76	0.4	VBMT 16 04 04-PMC	☆	*	☆	*
		15.8	4.76	0.8	VBMT 16 04 08-PMC	☆	*	☆	*	
		15.4	4.76	1.2	VBMT 16 04 12-PMC		*		*	
	UM	16	15.8	4.76	1.2	VBMT 16 04 08-UM				*

C

D



T-Max® P insert for turning

C-style insert (Rhombic 80°)

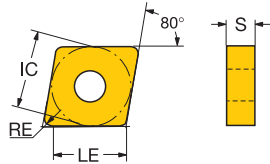
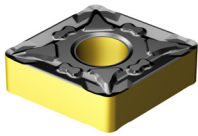

		LE	S	RE	BS	ISO CODE	P		K		S		
							4415	4425	4415	4425	S205		
Finishing	PF	19	15.3	11.00	4.0	CNMX 19 11 40-PF		★		★			
	MF	12	12.5	4.76	0.4	CNMG 12 04 04-MF	★	☆	☆	★	★		
			12.1	4.76	0.8	CNMG 12 04 08-MF	★	☆	☆	★	★		
			11.7	4.76	1.2	CNMG 12 04 12-MF	★	☆	☆	★	★		
	F	11.3	4.76	1.6		CNMG 12 04 16-MF	★		★				
		12	8.5	4.76	0.4	CNGG 12 04 04-SGF						★	
			8.5	4.76	0.8	CNGG 12 04 08-SGF						★	
			8.5	4.76	1.2	CNGG 12 04 12-SGF						★	
		PF	12	12.1	4.76	0.8	CNMU 12 04 08-PF	★					
Medium	PMC	12	12.5	4.76	0.4	CNMG 12 04 04-PMC		★			★		
			12.1	4.76	0.8	CNMG 12 04 08-PMC	☆	★	☆	★	★		
			11.7	4.76	1.2	CNMG 12 04 12-PMC	☆	★	☆	★	★		
		16	15.3	6.35	0.8	CNMG 16 06 08-PMC	☆	★	☆	★	★		
			14.9	6.35	1.2	CNMG 16 06 12-PMC	☆	★	☆	★	★		
		WM	16	15.3	6.35	0.8	0.9	CNMG 16 06 08-WM	★	★			
		QM	19	18.9	6.35	0.4	CNMG 19 06 04-QM	★		★			
	SM	16	15.3	6.35	0.8	CNMG 16 06 08-SM						★	
			10.6	6.35	1.2	CNMG 16 06 12-SM						★	
			10.6	6.35	1.6	CNMG 16 06 16-SM						★	
		19	12.7	6.35	1.6	CNMG 19 06 16-SM						★	
	HM	16	14.9	6.35	1.2	CNMG 16 06 12-HM	☆	★	☆	★	★		
			14.5	6.35	1.6	CNMG 16 06 16-HM	☆	★	☆	★	★		
		19	18.1	6.35	1.2	CNMG 19 06 12-HM	☆	★	☆	★	★		
			17.7	6.35	1.6	CNMG 19 06 16-HM	☆	★	☆	★	★		
			19.0	6.35	2.4	CNMG 19 06 24-HM	☆	★	☆	★	★		
	PM	12	11.7	4.76	1.2	CNMU 12 04 12-PM	☆	★					
			11.7	6.35	1.2	CNMU 12 06 12-PM	☆	★					
		QM	12	11.7	4.76	1.2	CNMU 12 04 12-QM	☆	★				
	SMR	12	8.5	4.76	0.8	CNMG 12 04 08-SMR						★	
		8.5	4.76	1.2	CNMG 12 04 12-SMR						★		
		8.5	4.76	1.6	CNMG 12 04 16-SMR						★		
Roughing	WR	12	12.1	4.76	0.8	1.0	CNMM 12 04 08-WR	☆	★	☆	★		
			11.3	4.76	1.6	1.4	CNMM 12 04 16-WR		★		★		
		16	14.9	6.35	1.2	1.4	CNMM 16 06 12-WR	★		★			
			14.5	6.35	1.6	1.5	CNMM 16 06 16-WR		★		★		
		19	17.7	6.35	1.6	1.5	CNMM 19 06 16-WR	☆	★	☆	★		
	PR	25	23.4	9.53	2.4		CNMG 25 09 24-PR		★		★		
		QR	25	23.4	9.53	2.4	CNMM 25 09 24-QR		★		★		
	HR	19	17.7	6.35	1.6		CNMM 19 06 16-HR	☆	★	☆	★		
			16.9	6.35	2.4		CNMM 19 06 24-HR	☆	★	☆	★		
25		23.4	9.53	2.4		CNMM 25 09 24-HR		★		★			
		22.6	9.53	3.2		CNMM 25 09 32-HR		★		★			

B

C

D

E



T-Max® P insert for turning

C-style insert (Rhombic 80°)

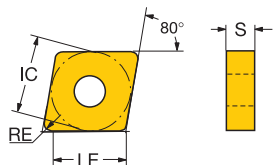
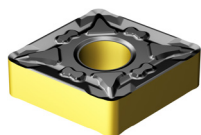

B

		LE	S	RE	BS	ISO CODE	P			K		S
							4415	4425	4415	4425	S205	
Roughing	MR	12	12.1	4.76	0.8	CNMG 12 04 08-MR	☆	★	☆	★		
		11.7	4.76	1.2		CNMG 12 04 12-MR	☆	★	☆	★		
		11.3	4.76	1.6		CNMG 12 04 16-MR	☆	★	☆	★		
		16	15.3	6.35	0.8	CNMG 16 06 08-MR	☆	★	☆	★		
		14.9	6.35	1.2		CNMG 16 06 12-MR	☆	★	☆	★		
		14.5	6.35	1.6		CNMG 16 06 16-MR	☆	★	☆	★		
		19	18.5	6.35	0.8	CNMG 19 06 08-MR	☆	★	☆	★		
		18.1	6.35	1.2		CNMG 19 06 12-MR	☆	★	☆	★		
		17.7	6.35	1.6		CNMG 19 06 16-MR	☆	★	☆	★		
		PR	12	11.3	4.76	1.6	CNMG 12 04 16-PR		★			
	11.3		6.35	1.6		CNMG 12 06 16-PR		★				
	XMR	16	14.5	6.35	1.6	CNMG 16 06 16-XMR	★		★			

C

D

E



86



T-Max® P insert for turning

D-style insert (Rhombic 55°)

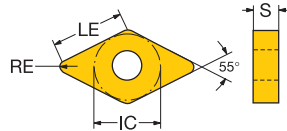
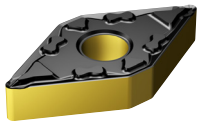

		LE	S	RE	BS	ISO CODE	P		K		S	
							4415	4425	4415	4425	S205	
Finishing	MF	15	15.1	4.76	0.4	DNMG 15 04 04-MF	★	☆	☆	★	★	
		14.7	4.76	0.8	DNMG 15 04 08-MF	★	☆	☆	★	★		
		15.1	6.35	0.4	DNMG 15 06 04-MF	★	☆	☆	★	★		
		14.7	6.35	0.8	DNMG 15 06 08-MF	★	☆	☆	★	★		
		14.3	6.35	1.2	DNMG 15 06 12-MF	★	☆	☆	★	★		
	MF	11	11.2	4.76	0.4	DNMG 11 04 04-MF	★		★			
		10.8	4.76	0.8	DNMG 11 04 08-MF	★		☆	★			
		10.4	4.76	1.2	DNMG 11 04 12-MF	★			★			
		15	14.3	4.76	1.2	DNMG 15 04 12-MF	★		★		★	
	K	15	15.1	4.76	0.4	DNMG 15 04 04R-K	★			★		
		14.7	4.76	0.8	DNMG 15 04 08R-K	★				★		
	SGF	15	6.4	4.76	0.4	DNGG 15 04 04-SGF						★
		6.4	4.76	0.8	DNGG 15 04 08-SGF							★
		6.4	6.35	0.4	DNGG 15 06 04-SGF							★
		6.4	6.35	0.8	DNGG 15 06 08-SGF							★
		6.4	6.35	1.2	DNGG 15 06 12-SGF							★
	XF	15	15.1	4.76	0.4	DNMG 15 04 04-XF		★			★	
		14.7	4.76	0.8	DNMG 15 04 08-XF		★			★		
		15.1	6.35	0.4	DNMG 15 06 04-XF		★			★		
	Medium	PMC	11	11.2	4.76	0.4	DNMG 11 04 04-PMC	☆	★	☆	★	
10.8			4.76	0.8	DNMG 11 04 08-PMC		★		★			
15			15.1	4.76	0.4	DNMG 15 04 04-PMC		★		★		
14.7			4.76	0.8	DNMG 15 04 08-PMC	☆	★	☆	★			
15.1			6.35	0.4	DNMG 15 06 04-PMC	☆	★	☆	★			
14.7			6.35	0.8	DNMG 15 06 08-PMC	☆	★	☆	★			
WM		15	14.3	4.76	1.2	0.8	DNMX 15 04 12-WM	☆	★	☆	★	
		13.9	4.76	1.6	1.0	DNMX 15 04 16-WM		★		★		
		15	14.7	4.76	0.8	DNMG 15 04 08-QM					★	
		11	11.2	4.76	0.4	DNMG 11 04 04-SM					★	
Roughing	XM	15	15.1	4.76	0.4	DNMG 15 04 04-XM		★		★		
		14.7	4.76	0.8	DNMG 15 04 08-XM	★			★			
	SMR	15	6.4	4.76	0.8	DNMG 15 04 08-SMR					★	
		6.4	4.76	1.2	DNMG 15 04 12-SMR						★	
		6.4	6.35	0.8	DNMG 15 06 08-SMR						★	
		6.4	6.35	1.2	DNMG 15 06 12-SMR						★	
		6.4	6.35	1.6	DNMG 15 06 16-SMR						★	
	PR	19	18.2	6.35	1.2	DNMG 19 06 12-PR	★			★		
	MR	15	14.7	4.76	0.8	DNMG 15 04 08-MR	☆	★	☆	★		
		14.3	4.76	1.2	DNMG 15 04 12-MR	★			★			
14.7		6.35	0.8	DNMG 15 06 08-MR	☆	★	☆	★				
14.3		6.35	1.2	DNMG 15 06 12-MR	☆	★	☆	★				
13.9		6.35	1.6	DNMG 15 06 16-MR	☆	★	☆	★				

T-Max® P insert for turning

R-style insert (Round)

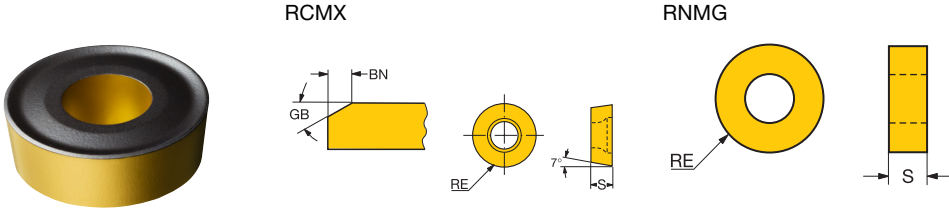

B

	S	RE	GB	BN	ISO CODE	P		K		
						4415	4425	4415	4425	
Medium 00	10	3.18	5.0	15°	0.20	RCMX 10 03 00	☆	★	☆	★
	12	4.76	6.0	15°	0.20	RCMX 12 04 00	☆	★	☆	★
	16	6.35	8.0	15°	0.25	RCMX 16 06 00	☆	★	☆	★
	20	6.35	10.0	15°	0.30	RCMX 20 06 00		★		★
	25	7.94	12.5	15°	0.40	RCMX 25 07 00		★		★
	32	9.53	16.0	15°	0.40	RCMX 32 09 00		★		★
	09	3.18	4.8			RNMG 09 03 00		★		★
	12	4.76	6.4			RNMG 12 04 00	☆	★	☆	★
	15	6.35	7.9			RNMG 15 06 00	☆	★	☆	★
	19	6.35	9.5			RNMG 19 06 00		★		★
	25	9.53	12.7			RNMG 25 09 00		★		★

C

D

E



T-Max® P insert for turning

S-style insert (Square)

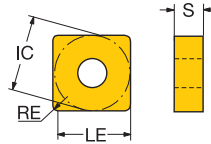
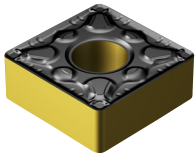

		LE	S	RE	ISO CODE	P		K		S	
						4415	4425	4415	4425	5205	
Finishing	MF	12	11.9	4.76	0.8	SNMG 12 04 08-MF	★	★	★	★	
			11.5	4.76	1.2	SNMG 12 04 12-MF	★	★	★	★	
Medium	PMC	12	11.5	4.76	1.2	SNMG 12 04 12-PMC		★		★	
	PM	15	14.3	6.35	1.6	SNMG 15 06 16-PM	★		★		
	QM	12	11.9	4.76	0.8	SNMG 12 04 08-QM					★
			11.1	4.76	1.6	SNMG 12 04 16-QM	★		★		
		15	14.7	6.35	1.2	SNMG 15 06 12-QM	★		★		
		19	17.5	6.35	1.6	SNMG 19 06 16-QM	★		★		
	SM	12	8.5	4.76	0.8	SNMG 12 04 08-SM					★
			8.5	4.76	1.2	SNMG 12 04 12-SM					★
			8.5	4.76	1.6	SNMG 12 04 16-SM					★
		15	10.6	6.35	1.2	SNMG 15 06 12-SM					★
	HM	19	12.7	6.35	1.6	SNMG 19 06 16-SM					★
		15	14.7	6.35	1.2	SNMG 15 06 12-HM	☆	★	☆	★	
			14.3	6.35	1.6	SNMG 15 06 16-HM	☆	★	☆	★	
		19	17.9	6.35	1.2	SNMG 19 06 12-HM	☆	★	☆	★	
			17.5	6.35	1.6	SNMG 19 06 16-HM	☆	★	☆	★	
		19.0	6.35	2.4	SNMG 19 06 24-HM	☆	★	☆	★		
25		23.0	9.53	2.4	SNMG 25 09 24-HM		★		★		
KM	12	11.1	4.76	1.6	SNMU 12 04 16-KM		★		★		
XM	12	11.5	4.76	1.2	SNMG 12 04 12-XM		★		★		
Roughing	SMR	12	8.5	4.76	0.8	SNMG 12 04 08-SMR					★
			8.5	4.76	1.2	SNMG 12 04 12-SMR					★
	MR	25	23.0	7.94	2.4	SNMM 25 07 24-MR	☆	★	☆	★	
	PR	19	18.3	6.35	0.8	SNMG 19 06 08-PR	★		★		
		25	23.8	7.94	1.6	SNMG 25 07 16-PR		★		★	
			23.0	7.94	2.4	SNMG 25 07 24-PR		★		★	
			23.0	9.53	2.4	SNMG 25 09 24-PR		★		★	
	QR	25	23.0	7.94	2.4	SNMM 25 07 24-QR		★		★	
	HR	19	17.5	6.35	1.6	SNMM 19 06 16-HR	☆	★	☆	★	
			16.7	6.35	2.4	SNMM 19 06 24-HR		★		★	
		25	23.0	7.94	2.4	SNMM 25 07 24-HR		★		★	
			22.2	7.94	3.2	SNMM 25 07 32-HR		★		★	
			23.0	9.53	2.4	SNMM 25 09 24-HR		★		★	
		22.2	9.53	3.2	SNMM 25 09 32-HR		★		★		
	MR	12	11.9	4.76	0.8	SNMG 12 04 08-MR	☆	★	☆	★	
		11.5	4.76	1.2	SNMG 12 04 12-MR	☆	★	☆	★		
		11.1	4.76	1.6	SNMG 12 04 16-MR	☆	★	☆	★		
15		14.7	6.35	1.2	SNMG 15 06 12-MR	☆	★	☆	★		
		14.3	6.35	1.6	SNMG 15 06 16-MR	☆	★	☆	★		
19		18.3	6.35	0.8	SNMG 19 06 08-MR		★		★		
		17.9	6.35	1.2	SNMG 19 06 12-MR	☆	★	☆	★		
	17.5	6.35	1.6	SNMG 19 06 16-MR	☆	★	☆	★			
XMR	12	11.9	4.76	0.8	SNMG 12 04 08-XMR		★		★		
		11.5	4.76	1.2	SNMG 12 04 12-XMR	☆	★	☆	★		
SMR	15	10.6	6.35	1.6	SNMG 15 06 16-SMR					★	
	19	12.7	6.35	1.6	SNMG 19 06 16-SMR					★	

B

C

D

E



T-Max® P insert for turning

T-style insert (Triangular)

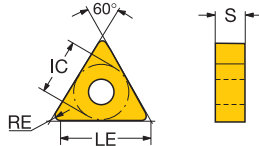
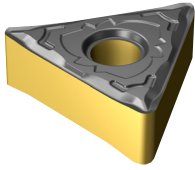

B

		LE	S	RE	BS	ISO CODE	P		K		S	
							4415	4425	4415	4425	S205	
Finishing	MF	11	10.8	3.18	0.2	TNMG 11 03 02-MF	★	☆	★	★		
			10.6	3.18	0.4	TNMG 11 03 04-MF	★	☆	★	★		
			10.2	3.18	0.8	TNMG 11 03 08-MF	★	☆	★	★		
			9.8	3.18	1.2	TNMG 11 03 12-MF		★		★		
		16	16.1	4.76	0.4	TNMG 16 04 04-MF	★	☆	★	★		
			15.7	4.76	0.8	TNMG 16 04 08-MF	★	☆	★	★		
		15.3	4.76	1.2	TNMG 16 04 12-MF	★	☆	★	★			
		14.9	4.76	1.6	TNMG 16 04 16-MF	★	☆	★	★			
	22	21.6	4.76	0.4	TNMG 22 04 04-MF		★		★			
		21.2	4.76	0.8	TNMG 22 04 08-MF	★	☆	★	★			
		20.8	4.76	1.2	TNMG 22 04 12-MF	★	☆	★	★			
		PF	16	15.7	4.76	0.8	TNMG 16 04 08-PF	★				
	WM	16	15.3	4.76	1.2	0.6	TNMG 16 04 12-WM	★	☆			
	SF	16	4.8	4.76	0.4	TNMG 16 04 04-SF					★	
			4.8	4.76	0.8	TNMG 16 04 08-SF					★	
Medium	PMC	16	15.7	4.76	0.8	TNMG 16 04 08-PMC	☆	★	☆	★		
	QM	27	26.7	6.35	0.8	TNMG 27 06 08-QM		★		★		
			26.3	6.35	1.2	TNMG 27 06 12-QM	☆	★	☆	★		
	SM	16	4.8	4.76	0.8	TNMG 16 04 08-SM					★	
			4.8	4.76	1.2	TNMG 16 04 12-SM					★	
	HM	27	27.0	6.35	1.2	TNMG 27 06 12-HM		★		★		
		33	33.0	9.53	2.4	TNMG 33 09 24-HM		★		★		
	Roughing	WR	22	20.8	4.76	1.2	1.3	TNMG 22 04 12-WR	★		★	
			20.4	4.76	1.6	1.4	TNMG 22 04 16-WR	★		★		
PR		27	26.7	6.35	0.8	TNMG 27 06 08-PR	☆	★	☆	★		
			26.3	6.35	1.2	TNMG 27 06 12-PR	☆	★	☆	★		
			25.9	6.35	1.6	TNMG 27 06 16-PR	☆	★	☆	★		
		33	31.4	7.94	1.6	TNMG 33 07 16-PR		★		★		
		30.6	9.53	2.4	TNMG 33 09 24-PR	☆	★	☆	★			
QR		22	21.2	4.76	0.8	TNMG 22 04 08-QR	★		★			
		27	25.9	6.35	1.6	TNMG 27 06 16-QR		★		★		
HR		27	25.9	6.35	1.6	TNMG 27 06 16-HR		★		★		
			25.1	6.35	2.4	TNMG 27 06 24-HR	☆	★	☆	★		
MR		16	15.7	4.76	0.8	TNMG 16 04 08-MR	☆	★	☆	★		
			15.3	4.76	1.2	TNMG 16 04 12-MR	☆	★	☆	★		
		22	21.2	4.76	0.8	TNMG 22 04 08-MR	☆	★	☆	★		
			20.8	4.76	1.2	TNMG 22 04 12-MR	☆	★	☆	★		
		20.4	4.76	1.6	TNMG 22 04 16-MR	☆	★	☆	★			
	19.6		4.76	2.4	TNMG 22 04 24-MR	★		★				
	27	26.7	6.35	0.8	TNMG 27 06 08-MR		★		★			
		26.3	6.35	1.2	TNMG 27 06 12-MR	☆	★	☆	★			
		25.9	6.35	1.6	TNMG 27 06 16-MR	☆	★	☆	★			
		33	30.6	9.53	2.4	TNMG 33 09 24-MR	☆	★	☆	★		

C

D

E



T-Max® P insert for turning

T-style insert (Triangular)

Insert for bar peeling

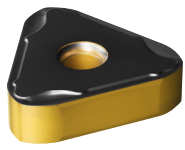

TNMX49-MF

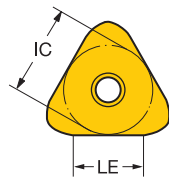

TNMX-2

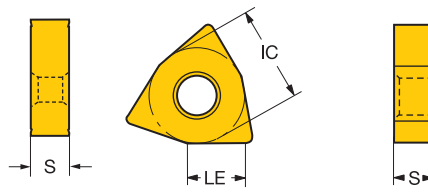

										P	
Finishing										4425	
	LE	S	RE	APMX	BS	KCH	CHW	ISO CODE	★		
	11	8.0	6.35	5.0	2.0	8.0	105°	7.0	TNMX 11 06-2		★
	15	13.0	9.53	5.0	3.0	13.0	105°	11.0	TNMX 15 09-2		★
49	21.0	10.00	12.0	2.5	21.0			TNMX 49 10 51-MF	★		

T-Max® P insert for turning

V-style insert (Rhombic 35°)

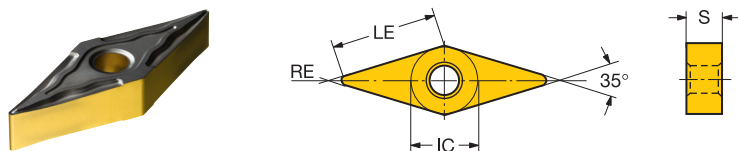

B

		LE	S	RE	ISO CODE	P		K		S	
						4415	4425	4415	4425	S205	
Finishing	MF	16	16.2	4.76	0.4	VNMG 16 04 04-MF	★		★		★
			15.8	4.76	0.8	VNMG 16 04 08-MF	★	☆	☆	★	★
			15.4	4.76	1.2	VNMG 16 04 12-MF		★		★	
	SGF	16	2.4	4.76	0.4	VNGG 16 04 04-SGF					★
			2.4	4.76	0.8	VNGG 16 04 08-SGF					★
			2.4	4.76	1.2	VNGG 16 04 12-SGF					★
Medium	PMC	16	16.2	4.76	0.4	VNMG 16 04 04-PMC	☆	★	☆	★	
			15.8	4.76	0.8	VNMG 16 04 08-PMC	☆	★	☆	★	
			15.4	4.76	1.2	VNMG 16 04 12-PMC		★		★	
	QM	16	15.4	4.76	1.2	VNMG 16 04 12-QM					★

C

D

E



86



T-Max® P insert for turning

W-style insert (Trigon 80°)

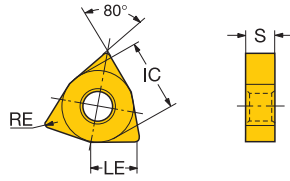
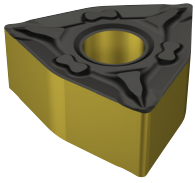

		LE	S	RE	BS	ISO CODE	P		K		S	
							4415	4425	4415	4425	S205	
Finishing	MF	06	6.1	4.76	0.4	WNMG 06 04 04-MF		★		★		
			5.7	4.76	0.8	WNMG 06 04 08-MF		★		★		
		08	8.3	4.76	0.4	WNMG 08 04 04-MF		★		★		
	SGF		7.9	4.76	0.8	WNMG 08 04 08-MF		★		★	★	
		08	3.2	4.76	0.4	WNGG 08 04 04-SGF						★
			3.2	4.76	0.8	WNGG 08 04 08-SGF						★
WM	08	7.5	4.76	1.2	1.1	WNMU 08 04 12-WM	★	☆				
Medium	PMC	08	8.3	4.76	0.4	WNMG 08 04 04-PMC	☆	★	☆	★		
			7.9	4.76	0.8	WNMG 08 04 08-PMC	☆	★	☆	★		
			7.5	4.76	1.2	WNMG 08 04 12-PMC	☆	★	☆	★		
	SMR	08	7.9	4.76	0.8	WNMG 08 04 08-SMR						★
Roughing	XMR	08	7.5	4.76	1.2	WNMG 08 04 12-XMR	★		★			
	MR	08	7.9	4.76	0.8	WNMG 08 04 08-MR	☆	★	☆	★		
			7.5	4.76	1.2	WNMG 08 04 12-MR	☆	★	☆	★		
			7.1	4.76	1.6	WNMG 08 04 16-MR	☆	★	☆	★		

B

C

D

E



T-Max® P insert for turning

W-style insert (Trigon 80°)

Insert for bar peeling

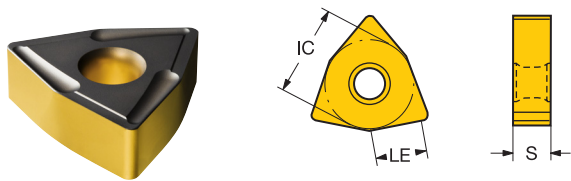

B

		LE	S	RE	APMX	BS	KCH	CHW	ISO CODE	P	
Medium	MM	21	15.0	12.70	16.0	5.0	7.5	100°	18.0	WNMX 21 12 51-MM	★
	PM	15	13.0	9.53	11.0	3.0	5.3	100°	11.0	WNMT 15 09 31-PM	★

C

D

E

T-Max® P insert for turning

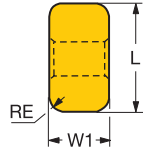
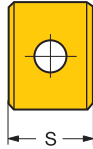

B

		 LE S RE W1 ISO CODE					P	K	
Medium	25	19	15.1	19.05	4.0	10.0	175.32-19 19 40-25	4425	4425
								*	*

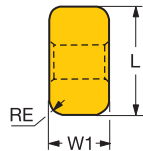
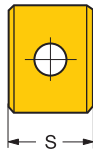

C

		 LE S RE W1 ISO CODE					P	
Finishing	PF	19	15.1	19.05	4.0	10.0	LNUX 19 19 40-PF	4425
								*
Medium	PM	19	15.1	19.05	4.0	10.0	LNMX 19 19 40-PM	*
		30	26.0	19.05	4.0	12.0	LNMX 30 19 40-PM	*
		19	15.1	19.05	4.0	10.0	LNUX 19 19 40-PM	*
Roughing	PR	30	26.0	19.05	4.0	12.0	LNMX 30 19 40-PR	*
			26.0	19.05	4.0	12.0	LNUX 30 19 40-PR	*

D

E



T-Max® P insert for turning

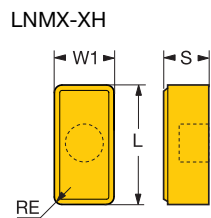
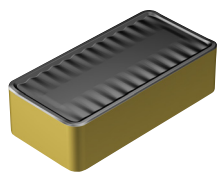

B

							P
							4425
		ISO CODE					★
Roughing	XH	50	34.0	14.20	3.2	25.4	LNMX 50 14 32-XH

C

D

E



86

T-Max® P cutting unit for turning

Rigid clamp design

Coromant Capto® - Precision coolant supply



KAPR
PSIR

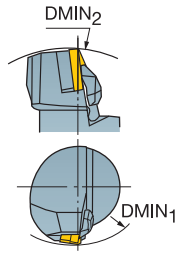

95.0°
-5.0°

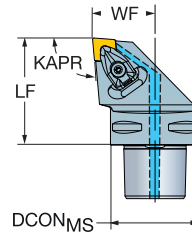

							Dimensions, mm, inch							MIID
			CZC _{MS}	DMIN ₁	DMIN ₂	CNSC	Ordering code	DCON _{MS}	LF	WF				
	12	1/2	C4	158.0	140.0	3	C4-DCLNR/L-27050-12B	40	50.0	27.0	150	3.9	0.41	CNMG 12 04 08
				6.220	5.512			1.575	1.969	1.063	2175			
		C5	158.0	165.0	3	C5-DCLNR/L-35060-12B	50	60.0	35.0	150	3.9	0.73	CNMG 12 04 08	
			6.220	6.496			1.969	2.362	1.378	2175				
	16	5/8	C6	165.0	190.0	3	C6-DCLNR/L-45065-16B	63	65.0	45.0	150	6.4	1.27	CNMG 16 06 12
				6.496	7.480			2.480	2.559	1.772	2175			
		C8	154.0	250.0	3	C8-DCLNR/L-55080-19B	80	80.0	55.0	150	6.4	2.59	CNMG 19 06 12	
			6.063	9.843			3.150	3.150	2.165	2175				

R = Right hand, L = Left hand

For complete list of spare parts, see www.sandvik.coromant.com



86



89

T-Max® P cutting unit for turning

Rigid clamp design

Coromant Capto® - Precision coolant supply

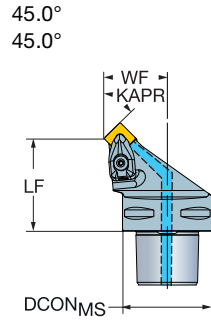
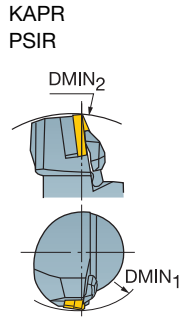

- SNMM
- SNMG
- SNMA, SNGA

	CZC _{MS}		DMIN ₁	DMIN ₂	CNSC	Ordering code	Dimensions, mm, inch						MIID		
	IC	IC					DCON _{MS}	LPR	LF	WF	BAR PSI	NM		KG	
	12	1/2	C4	127.0	140.0	3	C4-DSSNR/L-27042-12B	40	50.3	42.0	27.0	150	3.9	0.35	SNMG 12 04 08
			C5	5.000	5.512			1.575	1.981	1.654	1.063	2175			
				114.0	165.0	3	C5-DSSNR/L-35052-12B	50	60.3	52.0	35.0	150	3.9	0.67	SNMG 12 04 08
			4.488	6.496				1.969	2.375	2.047	1.378	2175			
	15	5/8	C6	159.0	190.0	3	C6-DSSNR/L-45054-15B	63	64.2	54.0	45.0	150	6.4	1.13	SNMG 15 06 12
				6.260	7.480			2.480	2.529	2.126	1.772	2175			

R = Right hand, L = Left hand

For complete list of spare parts, see www.sandvik.coromant.com



T-Max® P cutting unit for turning

Rigid clamp design

Coromant Capto® - Precision coolant supply

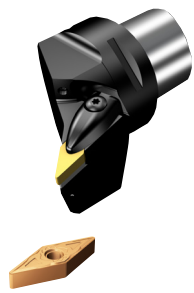

 VNMG





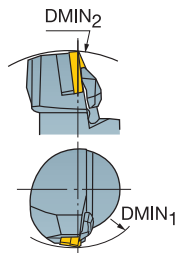

KAPR
PSIR

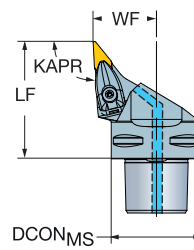

93.0°
-3.0°

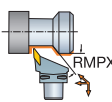

								Dimensions, mm, inch						MIID	
			CZC _{MS}	DMIN ₁	DMIN ₂	RMPX	CNSC	Ordering code	DCON _{MS}	LF	WF				
	16	3/8	C4	148.0	152.0	50°	3	C4-DVJNR/L-27062-16C	40	62.0	27.0	150	3.0	0.40	VNMG 16 04 08
				5.827	5.984				1.575	2.441	1.063	2175			
			C5	168.0	170.0	50°	3	C5-DVJNR/L-35065-16C	50	65.0	35.0	150	3.0	0.67	VNMG 16 04 08
				6.614	6.693				1.969	2.559	1.378	2175			
			C6	165.0	191.0	50°	3	C6-DVJNR/L-45065-16C	63	65.0	45.0	150	3.0	1.03	VNMG 16 04 08
				6.496	7.520				2.480	2.559	1.772	2175			
			C8	154.0	250.0	50°	3	C8-DVJNR/L-55080-16C	80	80.0	55.0	150	3.0	2.23	VNMG 16 04 08
				6.063	9.843				3.150	3.150	2.165	2175			

R = Right hand, L = Left hand

For complete list of spare parts, see www.sandvik.coromant.com



T-Max® insert for turning

R-style insert (Round)

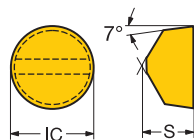
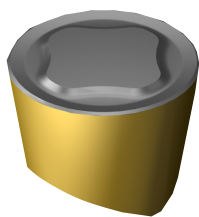

B

		S	RE	GB	BN	ISO CODE	S
Finishing	06	6.35	3.2	15°	0.10	RCGX 06 06 00-SF	★
	09	7.94	4.8	15°	0.10	RCGX 09 07 00-SF	★
Medium	06	6.35	3.2	15°	0.10	RCMX 06 06 00-SM	★
	09	7.94	4.8	15°	0.10	RCMX 09 07 00-SM	★
	12	7.94	6.4	15°	0.10	RCMX 12 07 00-SM	★

C

D

E



86

T-Max® insert for turning

ENG

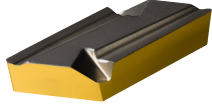

KNUX

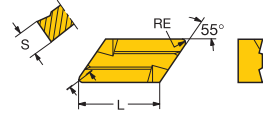

KNMX

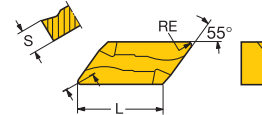

B

							P		K		
		LE	S	RE	W1	ISO CODE	4415	4425	4415	4425	
Finishing	71	16	16.0	4.76	0.5	9.5	KNMX 16 04 05 L-71	★	☆	☆	★
			16.0	4.76	0.5	9.5	KNMX 16 04 05 R-71	★	☆	☆	★
			15.5	4.76	1.0	9.5	KNMX 16 04 10 L-71	★	☆	☆	★
			15.5	4.76	1.0	9.5	KNMX 16 04 10 R-71	★	☆	☆	★
	11	16	16.0	4.76	0.5	9.5	KNUX 16 04 05L11	★	☆	☆	★
			16.0	4.76	0.5	9.5	KNUX 16 04 05R11	★	☆	☆	★
			15.5	4.76	1.0	9.5	KNUX 16 04 10L11	★	☆	☆	★
			15.5	4.76	1.0	9.5	KNUX 16 04 10R11	★	☆	☆	★
	12	16	16.0	4.76	0.5	9.5	KNUX 16 04 05L12	★	☆	☆	★
			16.0	4.76	0.5	9.5	KNUX 16 04 05R12	★	☆	☆	★
			15.5	4.76	1.0	9.5	KNUX 16 04 10L12	★	☆	☆	★
			15.5	4.76	1.0	9.5	KNUX 16 04 10R12	★	☆	☆	★

N = Neutral, R = Right hand, L = Left hand

C

D

E



CoroTurn® 111 insert for turning

C-style insert (Rhombic 80°)

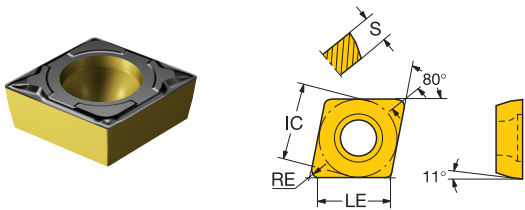

B

					P		K		
		LE	S	RE	4415	4425	4415	4425	
Finishing	PF	06	6.0	2.38	0.4	★	☆	★	★
		09	9.3	3.97	0.4	★	☆	★	★
			8.9	3.97	0.8	★	☆	★	★
ISO CODE									
Medium	PM	06	6.0	2.38	0.4	☆	★	☆	★
			5.6	2.38	0.8	☆	★	☆	★
		09	9.3	3.97	0.4	☆	★	☆	★
	UM		8.9	3.97	0.8	☆	★	☆	★
		09	9.3	3.97	0.4	☆	★	☆	★
			8.9	3.97	0.8	☆	★	☆	★

C

D

E

CoroTurn® 111 insert for turning

D-style insert (Rhombic 55°)

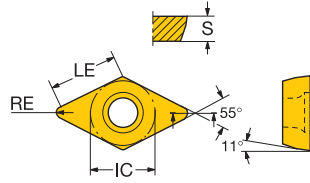
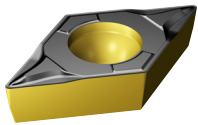

						P		K		
		LE	S	RE	ISO CODE	4415	4425	4415	4425	
Finishing	PF	07	7.4	2.38	0.4	DPMT 07 02 04-PF	★	☆	☆	★
Medium	PM	07	7.4	2.38	0.4	DPMT 07 02 04-PM	☆	★	☆	★
			7.0	2.38	0.8	DPMT 07 02 08-PM	☆	★	☆	★
		11	11.2	3.97	0.4	DPMT 11 T3 04-PM	☆	★	☆	★
			10.8	3.97	0.8	DPMT 11 T3 08-PM	☆	★	☆	★



CoroTurn® 111 insert for turning

T-style insert (Triangular)

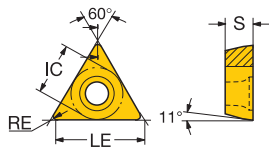
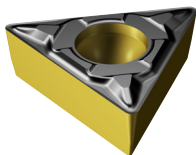

B

		LE	S	RE	ISO CODE	P		K		
						4415	4425	4415	4425	
Finishing	PF	06	6.2	1.91	0.4	TPMT 06 T1 04-PF	★	☆	★	★
		09	9.5	2.38	0.4	TPMT 09 02 04-PF	★	☆	★	★
		11	10.6	3.18	0.4	TPMT 11 03 04-PF	★	☆	★	★
		16	16.1	3.97	0.4	TPMT 16 T3 04-PF	★	☆	★	★
Medium	PM	09	9.5	2.38	0.4	TPMT 09 02 04-PM	☆	★	☆	★
		9.1	2.38	0.8	TPMT 09 02 08-PM	☆	★	☆	★	
		11	10.6	3.18	0.4	TPMT 11 03 04-PM	☆	★	☆	★
		10.2	3.18	0.8	TPMT 11 03 08-PM	☆	★	☆	★	
		16	16.1	3.97	0.4	TPMT 16 T3 04-PM	☆	★	☆	★
		15.7	3.97	0.8	TPMT 16 T3 08-PM	☆	★	☆	★	

C

D

E



CoroTurn® 111 insert for turning

W-style insert (Trigon 80°)

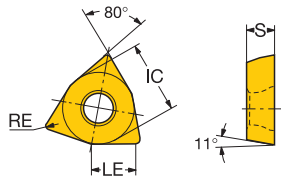
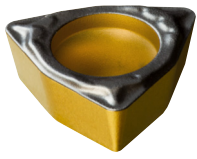

		LE	S	RE	ISO CODE	P		K		
						4415	4425	4415	4425	
Finishing	PF	02	2.2	1.59	0.4	WPMT 02 01 04-PF	*	*	*	*
		04	3.9	2.38	0.4	WPMT 04 02 04-PF	*	*	*	*
Medium	PM	04	3.9	2.38	0.4	WPMT 04 02 04-PM	*	*	*	*
			3.5	2.38	0.8	WPMT 04 02 08-PM	*	*	*	*

B

C

D

E

T-Max® S insert for turning

S-style insert (Square)

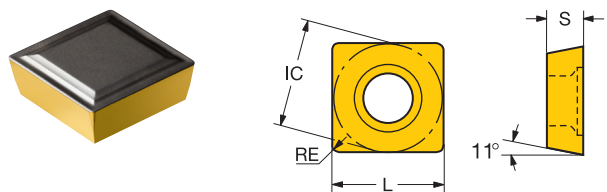

B

	LE	S	RE	ISO CODE	P	K	
					4425	4425	
Finishing S3	09	9.1	3.18	0.4	SPMR 09 03 04	★	★
		8.7	3.18	0.8	SPMR 09 03 08	★	★
	12	12.3	3.18	0.4	SPMR 12 03 04	★	★
		11.9	3.18	0.8	SPMR 12 03 08	★	★
		11.5	3.18	1.2	SPMR 12 03 12	★	★
	09	8.7	3.18	0.8	SPMR 09 03 08-53	★	★
	12	12.3	3.18	0.4	SPMR 12 03 04-53	★	★
		11.9	3.18	0.8	SPMR 12 03 08-53	★	★

C

D

E



T-Max® S insert for turning

T-style insert (Triangular)

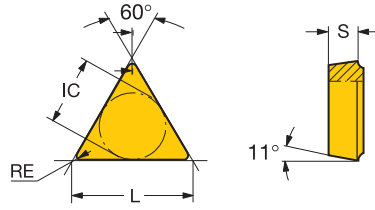
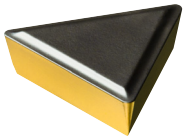

		LE	S	RE	ISO CODE	P	K	
						4425	4425	
Finishing	S3	09	9.5	2.38	0.4	TPMR 09 02 04	★	★
			9.1	2.38	0.8	TPMR 09 02 08	★	★
		11	10.6	3.18	0.4	TPMR 11 03 04	★	★
			10.2	3.18	0.8	TPMR 11 03 08	★	★
		16	16.1	3.18	0.4	TPMR 16 03 04	★	★
			15.7	3.18	0.8	TPMR 16 03 08	★	★
			15.3	3.18	1.2	TPMR 16 03 12	★	★
		22	21.2	4.76	0.8	TPMR 22 04 08	★	★
		20.8	4.76	1.2	TPMR 22 04 12	★	★	
	S3	11	10.6	3.18	0.4	TPMR 11 03 04-53	★	★
			10.2	3.18	0.8	TPMR 11 03 08-53	★	★
		16	16.1	3.18	0.4	TPMR 16 03 04-53	★	★
			15.7	3.18	0.8	TPMR 16 03 08-53	★	★



Parting and grooving

CoroCut® QI

Inserts

CoroCut® QI insert for grooving	35-37
CoroCut® QI insert for profiling	38

External tools

CoroCut® QI QS shank tool for face grooving	39-40
CoroCut® QI head for grooving	41
CoroCut® QI head for face grooving	42-43

Internal tools

CoroCut® QI boring bar for face grooving	44-45
CoroCut® QI boring bar for grooving	46-47

CoroCut® 1-2

Inserts

CoroCut® 1-2 insert for profiling	48-49
-----------------------------------	-------

CoroCut® QD

Inserts

CoroCut® QD insert for parting	50-51
CoroCut® QD insert for turning	52
CoroCut® QD insert for grooving	53

CoroCut® QI insert for grooving

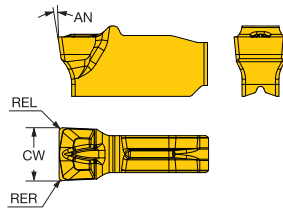

	SSC	CW	REL	RER	Ordering code	Dimensions, mm, inch																
						P		M			K	N		S			AN	CWTOLL	CWTOLU	RETOLL	RETOLU	
						1125	1145	1105	1125	1145	HI3A	1125	HI3A	1105	1125	HI3A						1105
Finishing	E	2.00	0.20	0.20	QI-NE-0200-0002-GF	*	*	*	*	*	*	*	*	*	*	*	*	8°	-0.020	0.020	-0.050	0.050
		.079	.008	.008																		
		2.39	0.20	0.20	QI-NE-0239-0002-GF	*	*	*	*	*	*	*	*	*	*	*	*	8°	-0.020	0.020	-0.050	0.050
		.094	.008	.008																		
		2.46	0.20	0.20	QI-NF-0246-0002-GF	*	*	*	*	*	*	*	*	*	*	*	*	8°	-0.020	0.020	-0.050	0.050
		.097	.008	.008																		
		2.67	0.20	0.20	QI-NF-0267-0002-GF	*	*	*	*	*	*	*	*	*	*	*	*	8°	-0.020	0.020	-0.050	0.050
		.105	.008	.008																		
		2.79	0.20	0.20	QI-NF-0279-0002-GF	*	*	*	*	*	*	*	*	*	*	*	*	8°	-0.020	0.020	-0.050	0.050
		.110	.008	.008																		
		3.00	0.20	0.20	QI-NG-0300-0002-GF	*	*	*	*	*	*	*	*	*	*	*	*	8°	-0.020	0.020	-0.050	0.050
		.118	.008	.008																		
	3.18	0.20	0.20	QI-NG-0318-0002-GF	*	*	*	*	*	*	*	*	*	*	*	*	8°	-0.020	0.020	-0.050	0.050	
	.125	.008	.008																			
	3.61	0.20	0.20	QI-NG-0361-0002-GF	*	*	*	*	*	*	*	*	*	*	*	*	8°	-0.020	0.020	-0.050	0.050	
	.142	.008	.008																			

SSC = To correspond with SSC on holder.

N = Neutral



A

PARTING AND GROOVING

Inserts

CoroCut® QI insert for grooving

For circlip grooves

B

		SSC CW REL RER				Ordering code	Dimensions, mm, inch															
							P		M		K		N		S							
							1125	1145	1125	1145	1125	1145	1125	1145	1125	1145	AN	CWTOLL	CWTOLU	RETOLL	RETOLU	
Finishing		E	1.85	0.10	0.10	QI-NE-0185-0001-GF	*	*	*	*	*	*	*	*	*	8°	0.090	0.130	-0.050	0.050		
			.073	.004	.004													.0035	.0051	-.0020	.0020	
			2.15	0.20	0.20	QI-NE-0215-0002-GF	*	*	*	*	*	*	*	*	*	8°	0.090	0.130	-0.050	0.050		
			.085	.008	.008														.0035	.0051	-.0020	.0020
		F	2.65	0.20	0.20	QI-NF-0265-0002-GF	*	*	*	*	*	*	*	*	*	8°	0.090	0.130	-0.050	0.050		
			.104	.008	.008														.0035	.0051	-.0020	.0020
		G	3.15	0.20	0.20	QI-NG-0315-0002-GF	*	*	*	*	*	*	*	*	*	8°	0.090	0.130	-0.050	0.050		
			.124	.008	.008														.0035	.0051	-.0020	.0020

SSC = To correspond with SSC on holder.

N = Neutral

C

D

E

86

A 36

ENG

CoroCut® QI insert for grooving

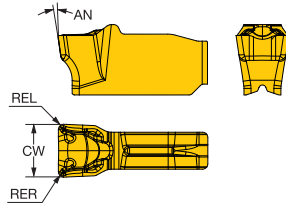
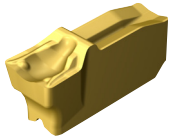

Finishing	SSC	CW	REL	RER	Ordering code	Dimensions, mm, inch																						
						P			M			K		N		S												
						1125	1135	1145	1105	1125	1135	1145	1125	1135	1105	1125	1135	1145	AN	CWTOLL	CWTOLU	RETOLL	RETOLU					
	G	3.00	0.30	0.30	QI-NG-0300-0003-TF	★	☆	☆	☆	☆	☆	★	☆	☆	★	☆	☆	★	☆	☆	★	☆	☆	8°	-0.050	0.050	-0.050	0.050
		.118	.012	.012																					-.0020	.0020	-.0020	.0020
	H	4.00	0.30	0.30	QI-NH-0400-0003-TF	★	☆	☆	☆	☆	☆	★	☆	☆	★	☆	☆	★	☆	☆	★	☆	☆	8°	-0.050	0.050	-0.050	0.050
		.157	.012	.012																					-.0020	.0020	-.0020	.0020
	J	5.00	0.40	0.40	QI-NJ-0500-0004-TF	★	☆	☆	☆	☆	☆	★	☆	☆	★	☆	☆	★	☆	☆	★	☆	☆	8°	-0.050	0.050	-0.050	0.050
		.197	.016	.016																					-.0020	.0020	-.0020	.0020
	K	6.00	0.40	0.40	QI-NK-0600-0004-TF	★	☆	☆	☆	☆	☆	★	☆	☆	★	☆	☆	★	☆	☆	★	☆	☆	8°	-0.050	0.050	-0.050	0.050
		.236	.016	.016																					-.0020	.0020	-.0020	.0020

SSC = To correspond with SSC on holder.

N = Neutral



A

PARTING AND GROOVING

Inserts

CoroCut® QI insert for profiling

B

	SSC	CW	RE	Ordering code	Dimensions, mm, inch															
					P		M		K		N		S		AN	CWTOLL	CWTOLU			
					1125	1135	1105	1125	1135	1125	1135	1105	1125	1105				1125	1135	
Medium	G	3.00	1.50	QI-NG-0300-RM	★	☆	☆	☆	★	★	★	★	★	★	★	★	8°	-0.050	0.050	
		.118	.059															-.0020	.0020	
	H	4.00	2.00	QI-NH-0400-RM	★	☆	☆	☆	★	★	★	★	★	★	★	★	8°	-0.050	0.050	
		.157	.079																-.0020	.0020
	J	5.00	2.50	QI-NJ-0500-RM	★	☆	☆	☆	★	★	★	★	★	★	★	★	8°	-0.050	0.050	
	.197	.098																-.0020	.0020	
	K	6.00	3.00	QI-NK-0600-RM	★	☆	☆	☆	★	★	★	★	★	★	★	8°	-0.050	0.050		
	.236	.118																-.0020	.0020	

SSC = To correspond with SSC on holder.

N = Neutral

C

D

E

86

A 38

ENG

CoroCut® QI QS shank tool for face grooving

Screw clamp design

Precision coolant supply

TSYC

QS-QI-RF..C..B

QS-QI-LF..C..B

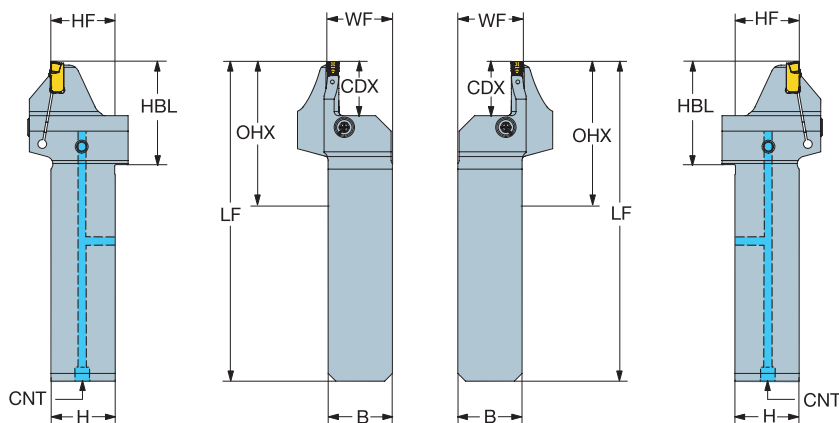
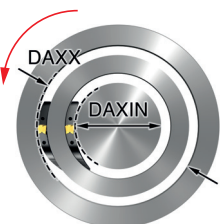
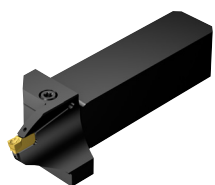

Metric version

SSC	CZC _{MS}	CDX	DAXIN	DAXX	OHX	CNSC	Ordering code	Dimensions, mm							MIID				
								B	H	HBL	LF	WF	HF	CNT		BAR	NM	KG	
G	25 x 25	15.0	16.0	30.0	60.0	3	QS-QI-LFG15C2525-016B	25.0	25.0	35.0	119.0	25.5	25.0	G 1/8-28	150	2.5	0.50	QI-NG-0300-0003-TF	
	25 x 25	15.0	24.0	40.0	60.0	3	QS-QI-LFG15C2525-024B	25.0	25.0	35.0	119.0	25.5	25.0	G 1/8-28	150	2.5	0.50	QI-NG-0300-0003-TF	
	25 x 25	20.0	16.0	32.0	65.0	3	QS-QI-LFH20C2525-016B	25.0	25.0	40.0	124.0	25.5	25.0	G 1/8-28	150	2.5	0.51	QI-NH-0400-0003-TF	
	25 x 25	20.0	24.0	44.0	65.0	3	QS-QI-LFH20C2525-024B	25.0	25.0	40.0	124.0	25.5	25.0	G 1/8-28	150	2.5	0.51	QI-NH-0400-0003-TF	
	25 x 25	20.0	23.0	45.0	65.0	3	QS-QI-LFJ20C2525-023B	25.0	25.0	40.0	124.0	25.5	25.0	G 1/8-28	150	2.5	0.52	QI-NJ-0500-0004-TF	
H	25 x 25	20.0	30.0	50.0	65.0	3	QS-QI-LFJ20C2525-030B	25.0	25.0	40.0	124.0	25.5	25.0	G 1/8-28	150	2.5	0.52	QI-NJ-0500-0004-TF	
	25 x 25	20.0	23.0	45.0	65.0	3	QS-QI-LFK20C2525-023B	25.0	25.0	40.0	124.0	25.5	25.0	G 1/8-28	150	2.5	0.53	QI-NK-0600-0004-TF	
	G	25 x 25	15.0	16.0	30.0	60.0	3	QS-QI-RFG15C2525-016B	25.0	25.0	35.0	119.0	25.5	25.0	G 1/8-28	150	2.5	0.50	QI-NG-0300-0003-TF
		25 x 25	15.0	24.0	40.0	60.0	3	QS-QI-RFG15C2525-024B	25.0	25.0	35.0	119.0	25.5	25.0	G 1/8-28	150	2.5	0.50	QI-NG-0300-0003-TF
		25 x 25	20.0	16.0	32.0	65.0	3	QS-QI-RFH20C2525-016B	25.0	25.0	40.0	124.0	25.5	25.0	G 1/8-28	150	2.5	0.51	QI-NH-0400-0003-TF
H	25 x 25	20.0	24.0	44.0	65.0	3	QS-QI-RFH20C2525-024B	25.0	25.0	40.0	124.0	25.5	25.0	G 1/8-28	150	2.5	0.51	QI-NH-0400-0003-TF	
	25 x 25	20.0	23.0	45.0	65.0	3	QS-QI-RFJ20C2525-023B	25.0	25.0	40.0	124.0	25.5	25.0	G 1/8-28	150	2.5	0.52	QI-NJ-0500-0004-TF	
	25 x 25	20.0	30.0	50.0	65.0	3	QS-QI-RFJ20C2525-030B	25.0	25.0	40.0	124.0	25.5	25.0	G 1/8-28	150	2.5	0.52	QI-NJ-0500-0004-TF	
K	25 x 25	20.0	23.0	45.0	65.0	3	QS-QI-RFK20C2525-023B	25.0	25.0	40.0	124.0	25.5	25.0	G 1/8-28	150	2.5	0.53	QI-NK-0600-0004-TF	

Inch version

SSC	CZC _{MS}	CDX	DAXIN	DAXX	OHX	CNSC	Ordering code	Dimensions, inch							MIID			
								B	H	HBL	LF	WF	HF	CNT		PSI	FT/LBS	LBS
G	1 x 1	.591	.630	1.181	2.362	3	QS-QI-LFG15C16-016B	1.000	1.000	1.378	4.685	1.020	1.000	G 1/8-28	2175	1.8	1.142	QI-NG-0300-0003-TF
	1 x 1	.591	.945	1.575	2.362	3	QS-QI-LFG15C16-024B	1.000	1.000	1.378	4.685	1.020	1.000	G 1/8-28	2175	1.8	1.146	QI-NG-0300-0003-TF
	1 x 1	.787	.630	1.260	2.559	3	QS-QI-LFH20C16-016B	1.000	1.000	1.575	4.882	1.020	1.000	G 1/8-28	2175	1.8	1.166	QI-NH-0400-0003-TF
	1 x 1	.787	.945	1.732	2.559	3	QS-QI-LFH20C16-024B	1.000	1.000	1.575	4.882	1.020	1.000	G 1/8-28	2175	1.8	1.160	QI-NH-0400-0003-TF
	1 x 1	.787	.906	1.772	2.559	3	QS-QI-LFK20C16-023B	1.000	1.000	1.575	4.882	1.020	1.000	G 1/8-28	2175	1.8	1.197	QI-NK-0600-0004-TF
H	1 x 1	.591	.630	1.181	2.362	3	QS-QI-RFG15C16-016B	1.000	1.000	1.378	4.685	1.020	1.000	G 1/8-28	2175	1.8	1.142	QI-NG-0300-0003-TF
	1 x 1	.591	.945	1.575	2.362	3	QS-QI-RFG15C16-024B	1.000	1.000	1.378	4.685	1.020	1.000	G 1/8-28	2175	1.8	1.146	QI-NG-0300-0003-TF
	1 x 1	.787	.630	1.260	2.559	3	QS-QI-RFH20C16-016B	1.000	1.000	1.575	4.882	1.020	1.000	G 1/8-28	2175	1.8	1.166	QI-NH-0400-0003-TF
	1 x 1	.787	.945	1.732	2.559	3	QS-QI-RFH20C16-024B	1.000	1.000	1.575	4.882	1.020	1.000	G 1/8-28	2175	1.8	1.160	QI-NH-0400-0003-TF
	1 x 1	.787	.906	1.772	2.559	3	QS-QI-RFK20C16-023B	1.000	1.000	1.575	4.882	1.020	1.000	G 1/8-28	2175	1.8	1.197	QI-NK-0600-0004-TF

SSC = To correspond with SSC on insert.

R = Right hand, L = Left hand

For complete list of spare parts, see www.sandvik.coromant.com



CoroCut® QI QS shank tool for face grooving

Screw clamp design

Precision coolant supply

TSYC

QS-QI-RG..C..B

QS-QI-LG..C..B

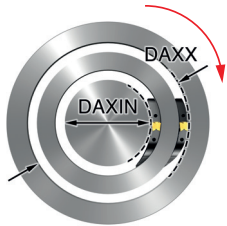
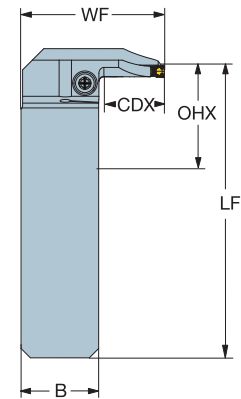
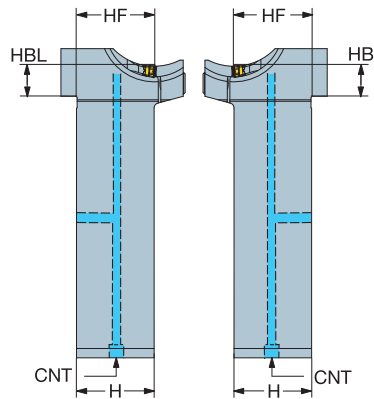
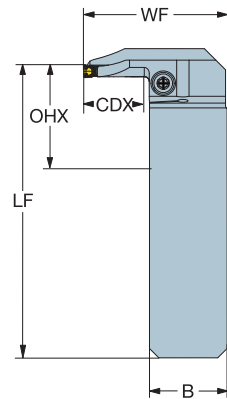

Metric version

								Dimensions, mm										MIID	
	SSC	CZC _{MS}	CDX	DAXIN	DAXX	OHX	CNSC	Ordering code	B	H	HBL	LF	WF	HF	CNT	BAR	NM		KG
	G	25 x 25	15.0	16.0	30.0	35.0	3	QS-QI-LGG15C2525-016B	25.0	25.0	10.0	94.0	41.0	25.0	G 1/8-28	150	2.5	0.45	QI-NG-0300-0003-TF
		25 x 25	15.0	24.0	40.0	35.0	3	QS-QI-LGG15C2525-024B	25.0	25.0	10.0	94.0	41.0	25.0	G 1/8-28	150	2.5	0.45	QI-NG-0300-0003-TF
	H	25 x 25	20.0	16.0	32.0	35.0	3	QS-QI-LGH20C2525-016B	25.0	25.0	10.0	94.0	46.0	25.0	G 1/8-28	150	2.5	0.47	QI-NH-0400-0003-TF
		25 x 25	20.0	24.0	44.0	35.0	3	QS-QI-LGH20C2525-024B	25.0	25.0	10.0	94.0	46.0	25.0	G 1/8-28	150	2.5	0.46	QI-NH-0400-0003-TF
	G	25 x 25	20.0	23.0	45.0	35.0	3	QS-QI-LGK20C2525-023B	25.0	25.0	10.0	94.0	46.0	25.0	G 1/8-28	150	2.5	0.48	QI-NK-0600-0004-TF
		25 x 25	15.0	24.0	40.0	35.0	3	QS-QI-RGG15C2525-016B	25.0	25.0	10.0	94.0	41.0	25.0	G 1/8-28	150	2.5	0.45	QI-NG-0300-0003-TF
	H	25 x 25	15.0	24.0	40.0	35.0	3	QS-QI-RGG15C2525-024B	25.0	25.0	10.0	94.0	41.0	25.0	G 1/8-28	150	2.5	0.45	QI-NG-0300-0003-TF
		25 x 25	20.0	16.0	32.0	35.0	3	QS-QI-RGH20C2525-016B	25.0	25.0	10.0	94.0	46.0	25.0	G 1/8-28	150	2.5	0.47	QI-NH-0400-0003-TF
K	25 x 25	20.0	24.0	44.0	35.0	3	QS-QI-RGH20C2525-024B	25.0	25.0	10.0	94.0	46.0	25.0	G 1/8-28	150	2.5	0.46	QI-NH-0400-0003-TF	
	25 x 25	20.0	23.0	45.0	35.0	3	QS-QI-RGK20C2525-023B	25.0	25.0	10.0	94.0	46.0	25.0	G 1/8-28	150	2.5	0.48	QI-NK-0600-0004-TF	

Inch version

								Dimensions, inch										MIID	
	SSC	CZC _{MS}	CDX	DAXIN	DAXX	OHX	CNSC	Ordering code	B	H	HBL	LF	WF	HF	CNT	PSI	FT/LBS		LBS
	G	1 x 1	.591	.630	1.181	1.378	3	QS-QI-LGG15C16-016B	1.000	1.000	.394	3.701	1.630	1.000	G 1/8-28	2175	1.8	1.129	QI-NG-0300-0003-TF
		1 x 1	.591	.945	1.575	1.378	3	QS-QI-LGG15C16-024B	1.000	1.000	.394	3.701	1.630	1.000	G 1/8-28	2175	1.8	1.034	QI-NG-0300-0003-TF
	H	1 x 1	.787	.630	1.260	1.378	3	QS-QI-LGH20C16-016B	1.000	1.000	.394	3.701	1.827	1.000	G 1/8-28	2175	1.8	1.063	QI-NH-0400-0003-TF
		1 x 1	.787	.945	1.732	1.378	3	QS-QI-LGH20C16-024B	1.000	1.000	.394	3.701	1.827	1.000	G 1/8-28	2175	1.8	1.058	QI-NH-0400-0003-TF
	G	1 x 1	.787	.906	1.772	1.378	3	QS-QI-LGK20C16-023B	1.000	1.000	.394	3.701	1.827	1.000	G 1/8-28	2175	1.8	1.096	QI-NK-0600-0004-TF
		1 x 1	.591	.630	1.181	1.378	3	QS-QI-RGG15C16-016B	1.000	1.000	.394	3.701	1.630	1.000	G 1/8-28	2175	1.8	1.032	QI-NG-0300-0003-TF
	H	1 x 1	.591	.945	1.575	1.378	3	QS-QI-RGG15C16-024B	1.000	1.000	.394	3.701	1.630	1.000	G 1/8-28	2175	1.8	1.034	QI-NG-0300-0003-TF
		1 x 1	.787	.630	1.260	1.378	3	QS-QI-RGH20C16-016B	1.000	1.000	.394	3.701	1.827	1.000	G 1/8-28	2175	1.8	1.063	QI-NH-0400-0003-TF
K	1 x 1	.787	.945	1.732	1.378	3	QS-QI-RGH20C16-024B	1.000	1.000	.394	3.701	1.827	1.000	G 1/8-28	2175	1.8	1.058	QI-NH-0400-0003-TF	
	1 x 1	.787	.906	1.772	1.378	3	QS-QI-RGK20C16-023B	1.000	1.000	.394	3.701	1.827	1.000	G 1/8-28	2175	1.8	1.096	QI-NK-0600-0004-TF	

SSC = To correspond with SSC on insert.

R = Right hand, L = Left hand

For complete list of spare parts, see www.sandvik.coromant.com

86

CoroCut® QI head for grooving

Screw clamp design

CoroTurn® SL - Precision coolant supply

TSYC

SL-QI-L..C

SL-QI-R..C

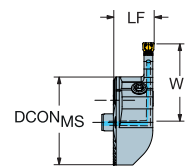
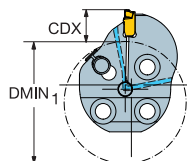
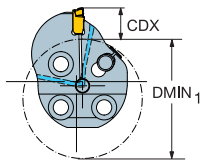
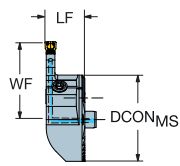

SSC	CZC _{MS}	CDX	DMIN ₁	CNSC	Ordering code	Dimensions, mm						MID	
						DCON _{MS}	LF	WF	BAR	NM	KG		
	E	25	8.0	36.0	1	SL-QI-LE08C25-36	25	14.0	22.3	150	3.0	0.03	QI-NE-0200-0002-GF
		32	8.0	43.0	1	SL-QI-LE08C32-43	32	14.0	25.0	150	3.0	0.06	QI-NE-0200-0002-GF
	F	25	8.0	40.0	1	SL-QI-LF08C25-40	25	14.0	22.3	150	3.0	0.03	QI-NF-0246-0002-GF
		32	7.0	42.0	1	SL-QI-LF07C32-42	32	14.0	24.0	150	3.0	0.06	QI-NF-0246-0002-GF
	G	25	5.0	32.0	1	SL-QI-LG05C25-32	25	14.0	19.3	150	3.0	0.03	QI-NG-0300-0002-GF
		25	8.0	41.0	1	SL-QI-LG08C25-41	25	14.0	22.3	150	3.0	0.03	QI-NG-0300-0002-GF
		32	8.0	43.0	1	SL-QI-LG08C32-43	32	14.0	25.0	150	3.0	0.06	QI-NG-0300-0002-GF
		40	6.0	49.0	1	SL-QI-LG06C40-49	40	14.0	27.8	150	3.0	0.14	QI-NG-0300-0002-GF
	H	25	5.0	32.0	1	SL-QI-LH05C25-32	25	14.0	19.3	150	3.0	0.03	QI-NH-0400-0003-TF
		32	7.0	40.0	1	SL-QI-LH07C32-40	32	14.0	23.8	150	3.0	0.06	QI-NH-0400-0003-TF
		32	10.0	48.0	1	SL-QI-LH10C32-48	32	14.0	28.0	150	3.0	0.06	QI-NH-0400-0003-TF
		40	9.0	52.0	1	SL-QI-LH09C40-52	40	14.0	30.8	150	3.0	0.10	QI-NH-0400-0003-TF
J	32	7.0	40.0	1	SL-QI-LJ07C32-40	32	14.0	23.8	150	3.0	0.06	QI-NJ-0500-0004-TF	
	32	10.0	49.0	1	SL-QI-LJ10C32-49	32	14.0	28.0	150	3.0	0.06	QI-NJ-0500-0004-TF	
	40	9.5	50.0	1	SL-QI-LJ09C40-50	40	14.0	29.5	150	3.0	0.14	QI-NJ-0500-0004-TF	
	40	9.0	52.0	1	SL-QI-LJ09C40-52	40	14.0	30.8	150	3.0	0.10	QI-NJ-0500-0004-TF	
	E	25	8.0	36.0	1	SL-QI-RE08C25-36	25	14.0	22.3	150	3.0	0.03	QI-NE-0200-0002-GF
		32	8.0	43.0	1	SL-QI-RE08C32-43	32	14.0	25.0	150	3.0	0.06	QI-NE-0200-0002-GF
	F	25	8.0	40.0	1	SL-QI-RF08C25-40	25	14.0	22.3	150	3.0	0.03	QI-NF-0246-0002-GF
		32	7.0	42.0	1	SL-QI-RF07C32-42	32	14.0	24.0	150	3.0	0.06	QI-NF-0246-0002-GF
	G	25	5.0	32.0	1	SL-QI-RG05C25-32	25	14.0	19.3	150	3.0	0.03	QI-NG-0300-0002-GF
		25	8.0	41.0	1	SL-QI-RG08C25-41	25	14.0	22.3	150	3.0	0.03	QI-NG-0300-0002-GF
		32	8.0	43.0	1	SL-QI-RG08C32-43	32	14.0	25.0	150	3.0	0.06	QI-NG-0300-0002-GF
		40	6.0	49.0	1	SL-QI-RG06C40-49	40	14.0	27.8	150	3.0	0.10	QI-NG-0300-0002-GF
	H	25	5.0	32.0	1	SL-QI-RH05C25-32	25	14.0	19.3	150	3.0	0.03	QI-NH-0400-0003-TF
		32	7.0	40.0	1	SL-QI-RH07C32-40	32	14.0	23.8	150	3.0	0.06	QI-NH-0400-0003-TF
		32	10.0	48.0	1	SL-QI-RH10C32-48	32	14.0	28.0	150	3.0	0.06	QI-NH-0400-0003-TF
		40	9.0	52.0	1	SL-QI-RH09C40-52	40	14.0	30.8	150	3.0	0.10	QI-NH-0400-0003-TF
J	32	7.0	40.0	1	SL-QI-RJ07C32-40	32	14.0	23.8	150	3.0	0.06	QI-NJ-0500-0004-TF	
	32	10.0	49.0	1	SL-QI-RJ10C32-49	32	14.0	28.0	150	3.0	0.06	QI-NJ-0500-0004-TF	
	40	9.5	50.0	1	SL-QI-RJ09C40-50	40	14.0	29.5	150	3.0	0.10	QI-NJ-0500-0004-TF	
	40	9.0	52.0	1	SL-QI-RJ09C40-52	40	14.0	30.8	150	3.0	0.10	QI-NJ-0500-0004-TF	

SSC = To correspond with SSC on insert.

R = Right hand, L = Left hand

For complete list of spare parts, see www.sandvik.coromant.com



A

PARTING AND GROOVING

External tools

CoroCut® QI head for face grooving

Screw clamp design

CoroTurn® SL - Precision coolant supply

ENG

TSYC

SL-QI-LF.C..A

SL-QI-RF.C..A

B

C

							Ordering code	Dimensions, mm						MIID
	SSC	CZC _{MS}	CDX	DAXIN	DAXX	CNSC		DCON _{MS}	LF	WF	BAR	NM	KG	
	G	32	8.7	24.0	35.0	1	SL-QI-LG08C32-024A	32	37.0	16.5	150	3.5	0.08	QI-NG-0300-0003-TF
		32	8.7	29.0	40.0	1	SL-QI-LG08C32-029A	32	37.0	16.5	150	3.5	0.08	QI-NG-0300-0003-TF
	H	32	8.7	27.0	45.0	1	SL-QI-LH08C32-027A	32	37.0	16.5	150	3.5	0.08	QI-NH-0400-0003-TF
		32	8.7	32.0	50.0	1	SL-QI-LH08C32-032A	32	37.0	16.5	150	3.5	0.08	QI-NH-0400-0003-TF
	G	32	8.7	24.0	35.0	1	SL-QI-RG08C32-024A	32	37.0	16.5	150	3.5	0.08	QI-NG-0300-0003-TF
		32	8.7	29.0	40.0	1	SL-QI-RG08C32-029A	32	37.0	16.5	150	3.5	0.08	QI-NG-0300-0003-TF
	H	32	8.7	27.0	45.0	1	SL-QI-RH08C32-027A	32	37.0	16.5	150	3.5	0.08	QI-NH-0400-0003-TF
	32	8.7	32.0	50.0	1	SL-QI-RH08C32-032A	32	37.0	16.5	150	3.5	0.08	QI-NH-0400-0003-TF	

SSC = To correspond with SSC on insert.

R = Right hand, L = Left hand

For complete list of spare parts, see www.sandvik.coromant.com

D

E

86

A 42

CoroCut® QI head for face grooving

Screw clamp design

CoroTurn® SL - Precision coolant supply

TSYC

SL-QI-LF.C..B

SL-QI-RF.C..B

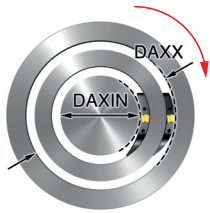
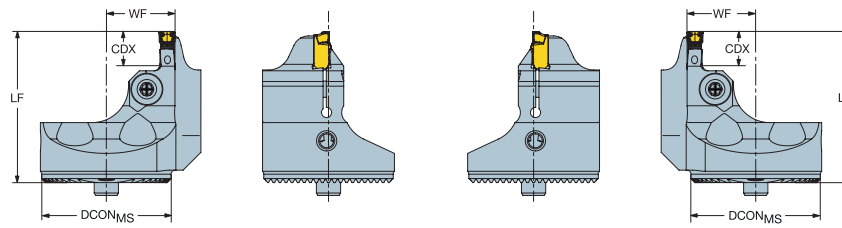
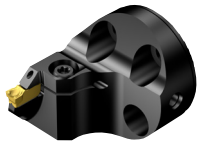

							Ordering code	Dimensions, mm						MIID
	SSC	CZC _{MS}	CDX	DAXIN	DAXX	CNSC		DCON _{MS}	LF	WF	BAR	NM	KG	
	G	32	8.7	24.0	35.0	1	SL-QI-LG08C32-024B	32	37.0	17.0	150	3.5	0.10	QI-NG-0300-0003-TF
		32	8.7	29.0	40.0	1	SL-QI-LG08C32-029B	32	37.0	17.0	150	3.5	0.10	QI-NG-0300-0003-TF
	H	32	8.7	27.0	45.0	1	SL-QI-LH08C32-027B	32	37.0	17.0	150	3.5	0.10	QI-NH-0400-0003-TF
		32	8.7	32.0	50.0	1	SL-QI-LH08C32-032B	32	37.0	17.0	150	3.5	0.10	QI-NH-0400-0003-TF
	G	32	8.7	24.0	35.0	1	SL-QI-RG08C32-024B	32	37.0	17.0	150	3.5	0.10	QI-NG-0300-0003-TF
		32	8.7	29.0	40.0	1	SL-QI-RG08C32-029B	32	37.0	17.0	150	3.5	0.10	QI-NG-0300-0003-TF
	H	32	8.7	27.0	45.0	1	SL-QI-RH08C32-027B	32	37.0	17.0	150	3.5	0.10	QI-NH-0400-0003-TF
	32	8.7	32.0	50.0	1	SL-QI-RH08C32-032B	32	37.0	17.0	150	3.5	0.10	QI-NH-0400-0003-TF	

SSC = To correspond with SSC on insert.

R = Right hand, L = Left hand

For complete list of spare parts, see www.sandvik.coromant.com



CoroCut® QI boring bar for face grooving

Screw clamp design

Cylindrical shank - Internal coolant supply

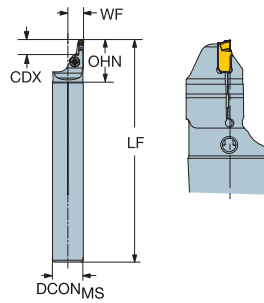
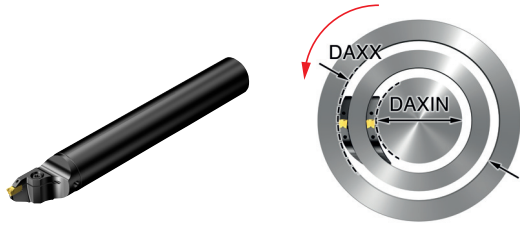

Metric version

For easy fix sleeves

	SSC	CZC _{MS}	CDX	DAXIN	DAXX	OHX	OHN	CNSC	Ordering code	Dimensions, mm						MIID
										DCON _{MS}	LF	WF	BAR	NM	KG	
	G	25	5.5	16.0	102.0	100.0	35.0	1	QI-LAFG05C25-016A	25	180.0	12.8	150	3.0	0.55	QI-NG-0300-0003-TF
		25	12.0	16.0	42.0	100.0	35.0	1	QI-LAFG12C25-016A	25	180.0	12.8	150	3.0	0.53	QI-NG-0300-0003-TF
		25	12.0	35.0	75.0	100.0	35.0	1	QI-LAFG12C25-035A	25	180.0	12.8	150	3.0	0.53	QI-NG-0300-0003-TF
	H	25	6.0	16.0	101.0	100.0	35.0	1	QI-LAFH06C25-016A	25	180.0	12.8	150	3.0	0.55	QI-NH-0400-0003-TF
		25	12.0	16.0	42.0	100.0	35.0	1	QI-LAFH12C25-016A	25	180.0	12.8	150	3.0	0.53	QI-NH-0400-0003-TF
		25	12.0	35.0	75.0	100.0	35.0	1	QI-LAFH12C25-035A	25	180.0	12.8	150	3.0	0.53	QI-NH-0400-0003-TF

Metric version

Cylindrical shank with flats

	SSC	CZC _{MS}	CDX	DAXIN	DAXX	OHX	OHN	CNSC	Ordering code	Dimensions, mm						MIID
										DCON _{MS}	LF	WF	BAR	NM	KG	
	K	40	7.0	23.0	80.0	120.0	45.0	1	QI-LAFK07C40-023A	40	200.0	20.3	150	4.0	1.54	QI-NK-0600-0004-TF
		40	15.0	23.0	60.0	120.0	45.0	1	QI-LAFK15C40-023A	40	200.0	20.3	150	4.0	1.49	QI-NK-0600-0004-TF

Inch version

For easy fix sleeves

	SSC	CZC _{MS}	CDX	DAXIN	DAXX	OHX	OHN	CNSC	Ordering code	Dimensions, inch						MIID
										DCON _{MS}	LF	WF	PSI	FT/LBS	LBS	
	G	1	.217	.630	4.016	3.937	1.378	1	QI-LAFG05C16-016A	1.000	7.087	.508	2175	2.2	1.254	QI-NG-0300-0003-TF
		1	.472	.630	1.654	3.937	1.378	1	QI-LAFG12C16-016A	1.000	7.087	.508	2175	2.2	1.208	QI-NG-0300-0003-TF
		1	.472	1.378	2.953	3.937	1.378	1	QI-LAFG12C16-035A	1.000	7.087	.508	2175	2.2	1.210	QI-NG-0300-0003-TF
	H	1	.236	.630	3.976	3.937	1.378	1	QI-LAFH06C16-016A	1.000	7.087	.508	2175	2.2	1.254	QI-NH-0400-0003-TF
		1	.472	.630	1.654	3.937	1.378	1	QI-LAFH12C16-016A	1.000	7.087	.508	2175	2.2	1.210	QI-NH-0400-0003-TF
		1	.472	1.378	2.953	3.937	1.378	1	QI-LAFH12C16-035A	1.000	7.087	.508	2175	2.2	1.215	QI-NH-0400-0003-TF

SSC = To correspond with SSC on insert.

R = Right hand, L = Left hand

For complete list of spare parts, see www.sandvik.coromant.com

86

CoroCut® QI boring bar for face grooving

Screw clamp design

Cylindrical shank - Internal coolant supply

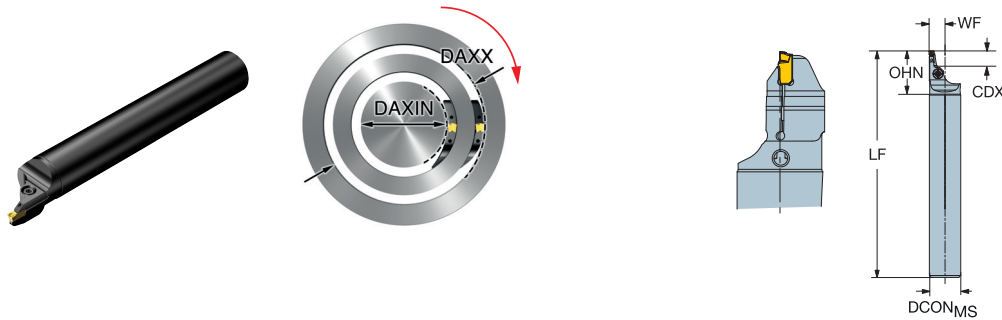

Metric version

For easy fix sleeves

									Ordering code	Dimensions, mm						MIID
	SSC	CZC _{MS}	CDX	DAXIN	DAXX	OHX	OHN	CNSC		DCON _{MS}	LF	WF	BAR	NM	KG	
	G	25	5.5	16.0	102.0	100.0	35.0	1	QI-RAFG05C25-016A	25	180.0	12.8	150	3.0	0.55	QI-NG-0300-0003-TF
		25	12.0	16.0	42.0	100.0	35.0	1	QI-RAFG12C25-016A	25	180.0	12.8	150	3.0	0.53	QI-NG-0300-0003-TF
		25	12.0	35.0	75.0	100.0	35.0	1	QI-RAFG12C25-035A	25	180.0	12.8	150	3.0	0.53	QI-NG-0300-0003-TF
	H	25	6.0	16.0	101.0	100.0	35.0	1	QI-RAFH06C25-016A	25	180.0	12.8	150	3.0	0.55	QI-NH-0400-0003-TF
		25	12.0	16.0	42.0	100.0	35.0	1	QI-RAFH12C25-016A	25	180.0	12.8	150	3.0	0.53	QI-NH-0400-0003-TF
		25	12.0	35.0	75.0	100.0	35.0	1	QI-RAFH12C25-035A	25	180.0	12.8	150	3.0	0.53	QI-NH-0400-0003-TF

Metric version

Cylindrical shank with flats

									Ordering code	Dimensions, mm						MIID	
	SSC	CZC _{MS}	CDX	DAXIN	DAXX	OHX	OHN	CNSC		DCON _{MS}	H	LF	WF	BAR	NM		KG
	K	40	7.0	23.0	80.0	120.0	45.0	1	QI-RAFK07C40-023A	40	37.0	200.0	20.3	150	4.0	1.54	QI-NK-0600-0004-TF
		40	15.0	23.0	60.0	120.0	45.0	1	QI-RAFK15C40-023A	40	37.0	200.0	20.3	150	4.0	1.49	QI-NK-0600-0004-TF

Inch version

For easy fix sleeves

									Ordering code	Dimensions, inch						MIID
	SSC	CZC _{MS}	CDX	DAXIN	DAXX	OHX	OHN	CNSC		DCON _{MS}	LF	WF	PSI	FT/LBS	LBS	
	G	1	.217	.630	4.016	3.937	1.378	1	QI-RAFG05C16-016A	1.000	7.087	.508	2175	2.2	1.254	QI-NG-0300-0003-TF
		1	.472	.630	1.654	3.937	1.378	1	QI-RAFG12C16-016A	1.000	7.087	.508	2175	2.2	1.208	QI-NG-0300-0003-TF
		1	.472	1.378	2.953	3.937	1.378	1	QI-RAFG12C16-035A	1.000	7.087	.508	2175	2.2	1.210	QI-NG-0300-0003-TF
	H	1	.236	.630	3.976	3.937	1.378	1	QI-RAFH06C16-016A	1.000	7.087	.508	2175	2.2	1.301	QI-NH-0400-0003-TF
		1	.472	.630	1.654	3.937	1.378	1	QI-RAFH12C16-016A	1.000	7.087	.508	2175	2.2	1.354	QI-NH-0400-0003-TF
		1	.472	1.378	2.953	3.937	1.378	1	QI-RAFH12C16-035A	1.000	7.087	.508	2175	2.2	1.356	QI-NH-0400-0003-TF

SSC = To correspond with SSC on insert.

R = Right hand, L = Left hand

For complete list of spare parts, see www.sandvik.coromant.com



CoroCut® QI boring bar for grooving

Screw clamp design

Cylindrical shank - Internal coolant supply

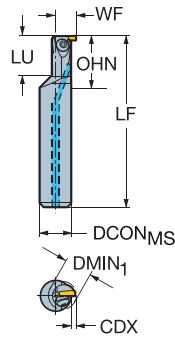

Metric version

SSC	CZC _{MS}	CDX	DMIN ₁	OHX	OHN	CNSC	Ordering code	Dimensions, mm					BAR	NM	KG	MIID
								DCON _{MS}	LF	WF	CNT					
E	16	3.5	20.0	64.0	25.0	1	QI-LAGE03C16-20	16	150.0	11.5	G 1/8-28	150	2.0	0.19	QI-NE-0200-0002-GF	
	20	4.5	25.0	80.0	30.0	1	QI-LAGE04C20-25	20	180.0	14.5	G 1/8-28	150	2.5	0.39	QI-NE-0200-0002-GF	
F	16	3.5	20.0	64.0	25.0	1	QI-LAGF03C16-20	16	150.0	11.5	G 1/8-28	150	2.0	0.19	QI-NF-0246-0002-GF	
	20	4.5	25.0	80.0	30.0	1	QI-LAGF04C20-25	20	180.0	14.5	G 1/8-28	150	2.5	0.39	QI-NF-0246-0002-GF	
G	25	6.0	32.0	100.0	32.0	1	QI-LAGF06C25-32	25	200.0	18.5	G 1/8-28	150	3.0	0.66	QI-NF-0246-0002-GF	
	20	4.5	25.0	80.0	30.0	1	QI-LAGG04C20-25	20	180.0	14.5	G 1/8-28	150	2.5	0.39	QI-NG-0300-0003-TF	
H	25	6.0	32.0	100.0	32.0	1	QI-LAGG06C25-32	25	200.0	18.5	G 1/8-28	150	3.0	0.66	QI-NG-0300-0003-TF	
	25	6.0	32.0	100.0	32.0	1	QI-LAGH06C25-32	25	200.0	18.5	G 1/8-28	150	3.0	0.66	QI-NH-0400-0003-TF	

SSC	CZC _{MS}	CDX	DMIN ₁	LU	OHX	OHN	CNSC	Ordering code	Dimensions, mm					BAR	NM	KG	MIID
									DCON _{MS}	LF	WF	CNT					
E	16	2.0	12.0	20.0	64.0	25.0	1	QI-LAGE02C16-12	16	150.0	10.0	G 1/8-28	150	1.2	0.18	QI-NE-0200-0002-GF	
F	16	4.0	15.0	20.0	64.0	25.0	1	QI-LAGF04C16-15	16	150.0	12.0	G 1/8-28	150	1.5	0.19	QI-NF-0246-0002-GF	
G	20	4.5	16.0	20.0	80.0	25.0	1	QI-LAGG04C20-16	20	180.0	14.3	G 1/8-28	150	2.0	0.37	QI-NG-0300-0003-TF	
H	20	5.0	18.0	20.0	80.0	25.0	1	QI-LAGH05C20-18	20	180.0	14.8	G 1/8-28	150	2.0	0.37	QI-NH-0400-0003-TF	

Inch version

SSC	CZC _{MS}	CDX	DMIN ₁	OHX	OHN	CNSC	Ordering code	Dimensions, inch					PSI	FT/LBS	LBS	MIID
								DCON _{MS}	LF	WF	CNT					
E	5/8	.138	.787	2.500	.984	1	QI-LAGE03C10-20	.625	5.906	.453	G 1/8-28	2175	1.5	.421	QI-NE-0200-0002-GF	
	3/4	.177	.984	3.000	1.181	1	QI-LAGE04C12-25	.750	7.087	.571	G 1/8-28	2175	1.8	.913	QI-NE-0200-0002-GF	
F	5/8	.138	.787	2.500	.984	1	QI-LAGF03C10-20	.625	5.906	.453	G 1/8-28	2175	1.5	.419	QI-NF-0246-0002-GF	
	3/4	.177	.984	3.000	1.181	1	QI-LAGF04C12-25	.750	7.087	.571	G 1/8-28	2175	1.8	.772	QI-NF-0246-0002-GF	
G	1	.236	1.260	4.000	1.260	1	QI-LAGF06C16-32	1.000	7.874	.736	G 1/8-28	2175	2.2	1.501	QI-NF-0246-0002-GF	
	3/4	.177	.984	3.000	1.181	1	QI-LAGG04C12-25	.750	7.087	.571	G 1/8-28	2175	1.8	.772	QI-NG-0300-0003-TF	
H	1	.236	1.260	4.000	1.260	1	QI-LAGG06C16-32	1.000	7.874	.736	G 1/8-28	2175	2.2	1.499	QI-NG-0300-0003-TF	
	1	.236	1.260	4.000	1.260	1	QI-LAGH06C16-32	1.000	7.874	.736	G 1/8-28	2175	2.2	1.499	QI-NH-0400-0003-TF	

SSC	CZC _{MS}	CDX	DMIN ₁	LU	OHX	OHN	CNSC	Ordering code	Dimensions, inch					PSI	FT/LBS	LBS	MIID
									DCON _{MS}	LF	WF	CNT					
E	5/8	.079	.472	.787	2.500	.984	1	QI-LAGE02C10-12	.625	5.906	.394	G 1/8-28	2175	0.9	.397	QI-NE-0200-0002-GF	
F	5/8	.157	.591	.787	2.500	.984	1	QI-LAGF04C10-15	.625	5.906	.472	G 1/8-28	2175	1.1	.406	QI-NF-0246-0002-GF	
G	3/4	.177	.630	.787	3.000	.984	1	QI-LAGG04C12-16	.750	7.087	.561	G 1/8-28	2175	1.5	.732	QI-NG-0300-0003-TF	
H	3/4	.197	.709	.787	3.000	.984	1	QI-LAGH05C12-18	.750	7.087	.581	G 1/8-28	2175	1.5	.741	QI-NH-0400-0003-TF	

SSC = To correspond with SSC on insert.

R = Right hand, L = Left hand



86

CoroCut® QI boring bar for grooving

Screw clamp design

Cylindrical shank - Internal coolant supply

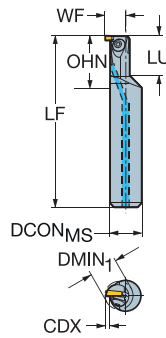

Metric version

SSC	CZC _{MS}	CDX	DMIN ₁	OHX	OHN	CNSC	Ordering code	Dimensions, mm						MIID	
								DCON _{MS}	LF	WF	CNT	BAR	NM		KG
E	16	3.5	20.0	64.0	25.0	1	QI-RAGE03C16-20	16	150.0	11.5	G 1/8-28	150	2.0	0.19	QI-NE-0200-0002-GF
	20	4.5	25.0	80.0	30.0	1	QI-RAGE04C20-25	20	180.0	14.5	G 1/8-28	150	2.5	0.39	QI-NE-0200-0002-GF
F	16	3.5	20.0	64.0	25.0	1	QI-RAGF03C16-20	16	150.0	11.5	G 1/8-28	150	2.0	0.19	QI-NF-0246-0002-GF
	20	4.5	25.0	80.0	30.0	1	QI-RAGF04C20-25	20	180.0	14.5	G 1/8-28	150	2.5	0.39	QI-NF-0246-0002-GF
G	25	6.0	32.0	100.0	32.0	1	QI-RAGG06C25-32	25	200.0	18.5	G 1/8-28	150	3.0	0.66	QI-NF-0246-0002-GF
	20	4.5	25.0	80.0	30.0	1	QI-RAGG04C20-25	20	180.0	14.5	G 1/8-28	150	2.5	0.39	QI-NG-0300-0003-TF
H	25	6.0	32.0	100.0	32.0	1	QI-RAGG06C25-32	25	200.0	18.5	G 1/8-28	150	3.0	0.66	QI-NG-0300-0003-TF
	25	6.0	32.0	100.0	32.0	1	QI-RAGH06C25-32	25	200.0	18.5	G 1/8-28	150	3.0	0.66	QI-NH-0400-0003-TF

SSC	CZC _{MS}	CDX	DMIN ₁	LU	OHX	OHN	CNSC	Ordering code	Dimensions, mm						MIID	
									DCON _{MS}	LF	WF	CNT	BAR	NM		KG
E	16	2.0	12.0	20.0	64.0	25.0	1	QI-RAGE02C16-12	16	150.0	10.0	G 1/8-28	150	1.2	0.18	QI-NE-0200-0002-GF
F	16	4.0	15.0	20.0	64.0	25.0	1	QI-RAGF04C16-15	16	150.0	12.0	G 1/8-28	150	1.5	0.19	QI-NF-0246-0002-GF
G	20	4.5	16.0	20.0	80.0	25.0	1	QI-RAGG04C20-16	20	180.0	14.3	G 1/8-28	150	2.0	0.37	QI-NG-0300-0003-TF
H	20	5.0	18.0	20.0	80.0	25.0	1	QI-RAGH05C20-18	20	180.0	14.8	G 1/8-28	150	2.0	0.37	QI-NH-0400-0003-TF

Inch version

SSC	CZC _{MS}	CDX	DMIN ₁	OHX	OHN	CNSC	Ordering code	Dimensions, inch						MIID	
								DCON _{MS}	LF	WF	CNT	PSI	FT/LBS		LBS
E	5/8	.138	.787	2.500	.984	1	QI-RAGE03C10-20	.625	5.906	.453	G 1/8-28	2175	1.5	.421	QI-NE-0200-0002-GF
	3/4	.177	.984	3.000	1.181	1	QI-RAGE04C12-25	.750	7.087	.571	G 1/8-28	2175	1.8	.772	QI-NE-0200-0002-GF
F	5/8	.138	.787	2.500	.984	1	QI-RAGF03C10-20	.625	5.906	.453	G 1/8-28	2175	1.5	.419	QI-NF-0246-0002-GF
	3/4	.177	.984	3.000	1.181	1	QI-RAGF04C12-25	.750	7.087	.571	G 1/8-28	2175	1.8	.913	QI-NF-0246-0002-GF
G	1	.236	1.260	4.000	1.260	1	QI-RAGF06C16-32	1.000	7.874	.736	G 1/8-28	2175	2.2	1.501	QI-NF-0246-0002-GF
	3/4	.177	.984	3.000	1.181	1	QI-RAGG04C12-25	.750	7.087	.571	G 1/8-28	2175	1.8	.772	QI-NG-0300-0003-TF
H	1	.236	1.260	4.000	1.260	1	QI-RAGG06C16-32	1.000	7.874	.736	G 1/8-28	2175	2.2	1.499	QI-NG-0300-0003-TF

SSC	CZC _{MS}	CDX	DMIN ₁	LU	OHX	OHN	CNSC	Ordering code	Dimensions, inch						MIID	
									DCON _{MS}	LF	WF	CNT	PSI	FT/LBS		LBS
E	5/8	.079	.472	.787	2.500	.984	1	QI-RAGE02C10-12	.625	5.906	.394	G 1/8-28	2175	0.9	.397	QI-NE-0200-0002-GF
F	5/8	.157	.591	.787	2.500	.984	1	QI-RAGF04C10-15	.625	5.906	.472	G 1/8-28	2175	1.1	.044	QI-NF-0246-0002-GF
G	3/4	.177	.630	.787	3.000	.984	1	QI-RAGG04C12-16	.750	7.087	.561	G 1/8-28	2175	1.5	.732	QI-NG-0300-0003-TF
H	3/4	.197	.709	.787	3.000	.984	1	QI-RAGH05C12-18	.750	7.087	.581	G 1/8-28	2175	1.5	.741	QI-NH-0400-0003-TF

SSC = To correspond with SSC on insert.

R = Right hand, L = Left hand

For complete list of spare parts, see www.sandvik.coromant.com



86

CoroCut® 1-2 insert for profiling



N123x1-RO

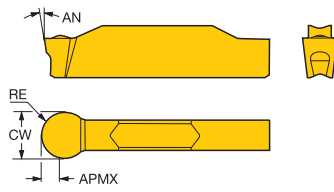

N123x2-RO

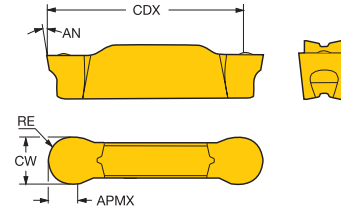

CoroCut® 1-edge

						s Dimensions, mm, inch						
		SSC	CW	RE	Ordering code	AN	CWTOLL	CWTOLU	RETOLL	RETOLU		
Finishing		F	3.00	1.50	N123F1-0300-RO	7°	-0.020	0.020	-0.010	0.010		
			.118	.059				-.0008	.0008	-.0004	.0004	
			3.18	1.59		N123F1-0318-RO	7°	-0.020	0.020	-0.010	0.010	
			.125	.063					-.0008	.0008	-.0004	.0004
		H	4.00	2.00		N123H1-0400-RO	7°	-0.020	0.020	-0.010	0.010	
			.157	.079					-.0008	.0008	-.0004	.0004
			4.75	2.38		N123H1-0475-RO	7°	-0.020	0.020	-0.010	0.010	
			.187	.094					-.0008	.0008	-.0004	.0004
			5.00	2.50		N123H1-0500-RO	7°	-0.020	0.020	-0.010	0.010	
			.197	.098					-.0008	.0008	-.0004	.0004
	J	6.00	3.00		N123J1-0600-RO	7°	-0.020	0.020	-0.010	0.010		
	.236	.118					-.0008	.0008	-.0004	.0004		
	L	8.00	4.00		N123L1-0800-RO	7°	-0.020	0.020	-0.010	0.010		
	.315	.157					-.0008	.0008	-.0004	.0004		

CoroCut® 2-edge

						s Dimensions, mm, inch						
		SSC	CW	RE	CDX	Ordering code	AN	CWTOLL	CWTOLU	RETOLL	RETOLU	
Finishing		E	2.00	1.00	19.2	N123E2-0200-RO	7°	-0.020	0.020	-0.010	0.010	
			.079	.039	.756				-.0008	.0008	-.0004	.0004
			2.39	1.20	19.0	N123E2-0239-RO	7°	-0.020	0.020	-0.010	0.010	
			.094	.047	.748				-.0008	.0008	-.0004	.0004
		F	3.00	1.50	18.7	N123F2-0300-RO	7°	-0.020	0.020	-0.010	0.010	
			.118	.059	.736				-.0008	.0008	-.0004	.0004
			3.18	1.59	18.6	N123F2-0318-RO	7°	-0.020	0.020	-0.010	0.010	
			.125	.063	.732				-.0008	.0008	-.0004	.0004
		H	3.96	1.98	23.3	N123H2-0396-RO	7°	-0.020	0.020	-0.010	0.010	
			.156	.078	.917				-.0008	.0008	-.0004	.0004
			4.00	2.00	23.3	N123H2-0400-RO	7°	-0.020	0.020	-0.010	0.010	
			.157	.079	.917				-.0008	.0008	-.0004	.0004
			4.75	2.38	22.9	N123H2-0475-RO	7°	-0.020	0.020	-0.010	0.010	
			.187	.094	.902				-.0008	.0008	-.0004	.0004
			5.00	2.50	22.8	N123H2-0500-RO	7°	-0.020	0.020	-0.010	0.010	
			.197	.098	.898				-.0008	.0008	-.0004	.0004
			J	6.00	3.00	22.2	N123J2-0600-RO	7°	-0.020	0.020	-0.010	0.010
			.236	.118	.874				-.0008	.0008	-.0004	.0004
			6.35	3.18	22.0	N123J2-0635-RO	7°	-0.020	0.020	-0.010	0.010	
			.250	.125	.866				-.0008	.0008	-.0004	.0004
	L	8.00	4.00	27.3	N123L2-0800-RO	7°	-0.020	0.020	-0.010	0.010		
	.315	.157	1.075				-.0008	.0008	-.0004	.0004		

SSC = To correspond with SSC on holder.

N = Neutral



CoroCut® 1-2 insert for profiling

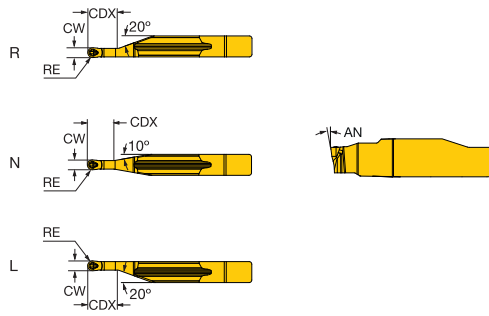
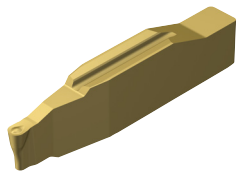

CoroCut® 1-edge

							S	Dimensions, mm, inch					
		SSC	CW	RE	CDX	APMX	Ordering code	SSC05	AN	CWTOLL	CWTOLU	RETOLL	RETOLU
Finishing		HL	1.50	0.75	4.0	0.5	L123H1-0150-RO	★	7°	-0.020	0.020	-0.010	0.010
			.059	.030	.157	.020				-0.008	.008	-0.004	.004
			2.00	1.00	5.0	0.8	L123H1-0200-RO	★	7°	-0.020	0.020	-0.010	0.010
			.079	.039	.197	.031				-0.008	.008	-0.004	.004
		HN	1.50	0.75	4.0	0.5	N123H1-0150-RO	★	7°	-0.020	0.020	-0.010	0.010
			.059	.030	.157	.020				-0.008	.008	-0.004	.004
			2.00	1.00	5.0	0.8	N123H1-0200-RO	★	7°	-0.020	0.020	-0.010	0.010
			.079	.039	.197	.031				-0.008	.008	-0.004	.004
		HR	1.50	0.75	4.0	0.5	R123H1-0150-RO	★	7°	-0.020	0.020	-0.010	0.010
	.059	.030	.157	.020				-0.008	.008	-0.004	.004		
	2.00	1.00	5.0	0.8	R123H1-0200-RO	★	7°	-0.020	0.020	-0.010	0.010		
	.079	.039	.197	.031				-0.008	.008	-0.004	.004		

SSC = To correspond with SSC on holder.

N = Neutral, R = Right hand, L = Left hand



A

CoroCut® QD insert for parting

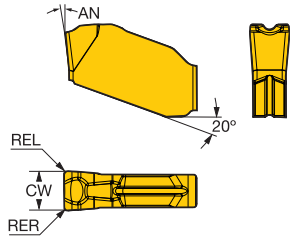

B

						P	K	Dimensions, mm, inch				
		SSC	CW	REL	RER	4425	4425	AN	CWTOLL	CWTOLU	RETOLL	RETOLU
Medium		G	3.00	0.30	0.30	☆	☆	7°	-0.050	0.050	-0.050	0.050
			.118	.012	.012				-.0020	.0020	-.0020	.0020
		H	4.00	0.30	0.30	☆	☆	7°	-0.050	0.050	-0.050	0.050
			.157	.012	.012				-.0020	.0020	-.0020	.0020
		J	5.00	0.40	0.40	☆	☆	7°	-0.050	0.050	-0.050	0.050
	.197	.016	.016				-.0020	.0020	-.0020	.0020		
	L	8.00	0.40	0.40	☆	☆	7°	-0.050	0.050	-0.050	0.050	
		.315	.016	.016				-.0020	.0020	-.0020	.0020	

C



Wiper TECHNOLOGY

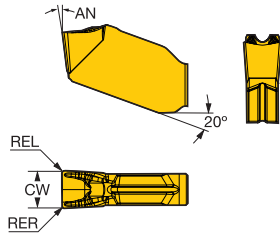

D

						P	K	Dimensions, mm, inch				
		SSC	CW	REL	RER	4425	4425	AN	CWTOLL	CWTOLU	RETOLL	RETOLU
Finishing		G	3.00	0.15	0.15	☆	☆	7°	-0.050	0.050	-0.050	0.050
			.118	.006	.006				-.0020	.0020	-.0020	.0020

SSC = To correspond with SSC on holder.

N = Neutral



CoroCut® QD insert for parting



QD-N...-CM

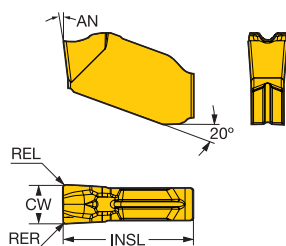

QD-N...-CR

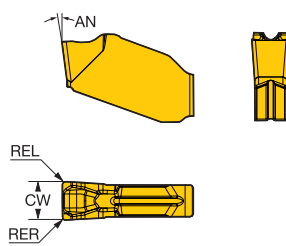

						P	K	Dimensions, mm, inch						
		SSC	CW	REL	RER	Ordering code	4425	4425	AN	CWTOLL	CWTOLU	RETOLL	RETOLU	
Medium		E	2.00	0.20	0.20	QD-NE-0200-0002-CM	☆	☆	7°	-0.050	0.050	-0.050	0.050	
			.079	.008	.008					-0.020	.0020	-0.020	.0020	
		F	2.50	0.20	0.20	QD-NF-0250-0002-CM	☆	☆	7°	-0.050	0.050	-0.050	0.050	
			.098	.008	.008						-0.020	.0020	-0.020	.0020
		G	3.00	0.20	0.20	QD-NG-0300-0002-CM	☆	☆	7°	-0.050	0.050	-0.050	0.050	
			.118	.008	.008						-0.020	.0020	-0.020	.0020
			3.00	0.40	0.40	QD-NG-0300-0004-CM	☆	☆	7°	-0.050	0.050	-0.050	0.050	
			.118	.016	.016						-0.020	.0020	-0.020	.0020
			3.18	0.20	0.20	QD-NG-0318-0002-CM	☆	☆	7°	-0.050	0.050	-0.050	0.050	
			.125	.008	.008						-0.020	.0020	-0.020	.0020
Roughing		H	4.00	0.20	0.20	QD-NH-0400-0002-CM	☆	☆	7°	-0.050	0.050	-0.050	0.050	
			.157	.008	.008						-0.020	.0020	-0.020	.0020
			4.00	0.40	0.40	QD-NH-0400-0004-CM	☆	☆	7°	-0.050	0.050	-0.050	0.050	
			.157	.016	.016						-0.020	.0020	-0.020	.0020
		J	5.00	0.20	0.20	QD-NJ-0500-0002-CM	☆	☆	7°	-0.050	0.050	-0.050	0.050	
			.197	.008	.008						-0.020	.0020	-0.020	.0020
		K	6.00	0.30	0.30	QD-NK-0600-0003-CM	☆	☆	7°	-0.050	0.050	-0.050	0.050	
			.236	.012	.012						-0.020	.0020	-0.020	.0020
			G	3.00	0.30	0.30	QD-NG-0300-0003-CR	☆	☆	7°	-0.050	0.050	-0.050	0.050
			.118	.012	.012						-0.020	.0020	-0.020	.0020
	H	4.00	0.30	0.30	QD-NH-0400-0003-CR	☆	☆	7°	-0.050	0.050	-0.050	0.050		
	.157	.012	.012						-0.020	.0020	-0.020	.0020		
	J	5.00	0.40	0.40	QD-NJ-0500-0004-CR	☆	☆	7°	-0.050	0.050	-0.050	0.050		
	.197	.016	.016						-0.020	.0020	-0.020	.0020		
	K	6.00	0.40	0.40	QD-NK-0600-0004-CR	☆	☆	7°	-0.050	0.050	-0.050	0.050		
	.236	.016	.016						-0.020	.0020	-0.020	.0020		

SSC = To correspond with SSC on holder.

N = Neutral



A

CoroCut® QD insert for turning

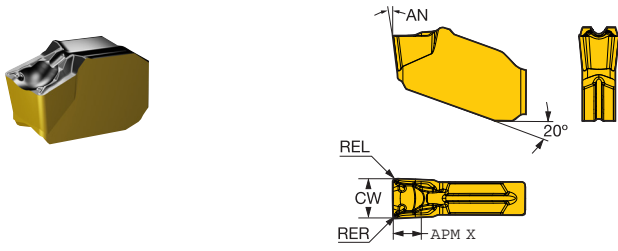

B

						P	K	Dimensions, mm, inch				
		SSC	CW	REL	RER	4425	4425	AN	CWTOLL	CWTOLU	RETOLL	RETOLU
Finishing		L	8.00	0.80	0.80	☆	☆	7°	-0.050	0.050	-0.050	0.050
			.315	.031	.031				-0.020	.0020	-0.020	.0020

SSC = To correspond with SSC on holder.

N = Neutral

C

D

E



86

CoroCut® QD insert for grooving

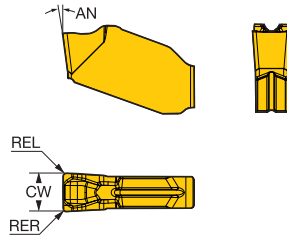

						P	K	Dimensions, mm, inch					
Medium		SSC	CW	REL	RER	Ordering code	4425	4425	AN	CWTOLL	CWTOLU	RETOLL	RETOLU
		K	6.00	0.40	0.40	QD-NK-0600-0004-GM	☆	☆	7°	-0.050	0.050	-0.050	0.050
			.236	.016	.016					-.0020	.0020	-.0020	.0020
		L	8.00	0.80	0.80	QD-NL-0800-0008-GM	☆	☆	7°	-0.050	0.050	-0.050	0.050
		.315	.031	.031					-.0020	.0020	-.0020	.0020	

SSC = To correspond with SSC on holder.

N = Neutral



Milling

ENG

CoroMill® MH20	
CoroMill® MH20 high-feed milling cutter	55-56
CoroMill® MH20 insert for milling	57

B

C

D

E

CoroMill® MH20 high-feed milling cutter

Cylindrical shank - Internal coolant supply

KAPR

15°

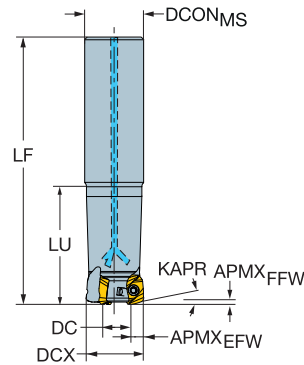
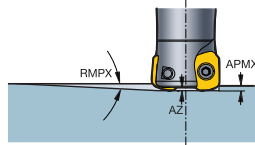

Metric version

											Dimensions, mm						
DCX	DC	SSC	CZC _{MS}	APMX _{EFW}	APMX _{FFW}	RMPX	AZ	CNSC		Ordering code	DCON _{MS}	LF	LU			RPMX	MIID
16.0	8.2	06	16	4.2	0.80	9.50°	0.7	1	2	MH20-R016A16-06L	16.0	100.0	40.0	0.9	0.13	26200	MH20-060320..
20.0	10.4	08	20	5.3	1.20	9.60°	0.9	1	2	MH20-R020A20-08L	20.0	120.0	40.0	1.4	0.25	23400	MH20-080425..
	12.2	06	20	4.2	0.80	5.80°	0.7	1	2	MH20-R020A20-06L	20.0	180.0	80.0	0.9	0.38	16900	MH20-060320..
	12.2	06	20	4.2	0.80	5.80°	0.7	1	3	MH20-R020A20-06M	20.0	120.0	40.0	0.9	0.25	23400	MH20-060320..
25.0	15.4	08	25	5.3	1.20	5.70°	0.9	1	2	MH20-R025A25-08L	25.0	200.0	100.0	2.0	0.66	18900	MH20-080425..
	15.4	08	25	5.3	1.20	5.70°	0.9	1	3	MH20-R025A25-08M	25.0	150.0	50.0	2.0	0.50	20900	MH20-080425..
	17.2	06	25	4.2	0.80	3.70°	0.7	1	3	MH20-R025A25-06M	25.0	200.0	80.0	0.9	0.68	18900	MH20-060320..
	17.2	06	25	4.2	0.80	3.70°	0.7	1	4	MH20-R025A25-06H	25.0	150.0	50.0	0.9	0.51	20900	MH20-060320..
32.0	22.4	08	32	5.3	1.20	3.60°	0.9	1	3	MH20-R032A32-08L	32.0	210.0	100.0	2.0	1.15	18500	MH20-080425..
	22.4	08	32	5.3	1.20	3.60°	0.9	1	4	MH20-R032A32-08M	32.0	150.0	60.0	2.0	0.82	18500	MH20-080425..

Inch version

											Dimensions, inch						
DCX	DC	SSC	CZC _{MS}	APMX _{EFW}	APMX _{FFW}	RMPX	AZ	CNSC		Ordering code	DCON _{MS}	LF	LU			RPMX	MIID
.625	.322	06	5/8	.165	.031	10.10°	.028	1	2	MH20-AR016016-06L	.625	3.937	1.575	.6	0.28	26300	MH20-060320..
.750	.418	08	3/4	.209	.047	10.70°	.035	1	2	MH20-AR019019-08L	.750	4.724	1.575	1.0	0.49	24000	MH20-080425..
.443	.06	3/4	.165	.031	6.50°	.028	1	2	MH20-AR019019-06L	.750	7.087	3.150	.6	0.85	15500	MH20-060320..	
.443	.06	3/4	.165	.031	6.50°	.028	1	3	MH20-AR019019-06M	.750	4.724	1.575	.6	0.56	24000	MH20-060320..	
1.000	.622	08	1	.209	.047	5.50°	.035	1	2	MH20-AR025025-08L	1.000	7.874	3.937	1.4	1.50	19500	MH20-080425..
.622	.08	1	.209	.047	5.50°	.035	1	3	MH20-AR025025-08M	1.000	5.906	1.969	1.4	0.99	20700	MH20-080425..	
.693	.08	1	.165	.031	3.60°	.028	1	3	MH20-AR025025-06M	1.000	7.874	3.937	.6	1.53	19500	MH20-060320..	
.693	.06	1	.165	.031	3.60°	.028	1	4	MH20-AR025025-06H	1.000	5.906	1.969	.6	1.17	20700	MH20-060320..	
1.250	.872	08	1 1/4	.209	.047	3.60°	.035	1	3	MH20-AR032032-08L	1.250	8.268	3.937	1.4	2.49	18600	MH20-080425..
.872	.08	1 1/4	.209	.047	3.60°	.035	1	4	MH20-AR032032-08M	1.250	5.906	2.362	1.4	1.85	18600	MH20-080425..	
1.500	1.122	08	1 1/4	.209	.047	2.70°	.035	2	4	MH20-AR038032-08M	1.250	9.843	4.724	1.4	3.26	15800	MH20-080425..
1.122	.08	1 1/4	.209	.047	2.70°	.035	1	5	MH20-AR038032-08H	1.250	8.268	3.150	1.4	2.72	16900	MH20-080425..	

	Spare parts
SSC	Insert screw
06	5513 020-48
08	5513 020-64



CoroMill® MH20 high-feed milling cutter

Coromant EH - Internal coolant supply

KAPR 15°

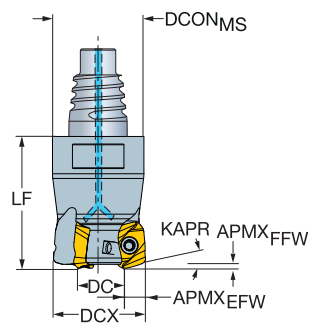
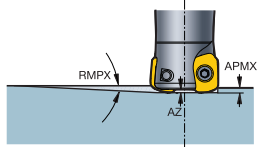

Metric version

											Dimensions, mm					
DCX	DC	SSC	CZC _{MS}	APMX _{EFW}	APMX _{FFW}	RMPX	AZ	CNSC		Ordering code	DCON _{MS}	LF			RPMX	MIID
16.0	8.2	06	E16	4.2	0.80	9.50°	0.7	1	2	MH20-R016EH16-06L	15.5	27.0	0.9	0.04	26200	MH20-060320..
20.0	10.4	08	E20	5.3	1.20	5.80°	0.9	1	2	MH20-R020EH20-08L	19.3	30.0	1.4	0.06	23400	MH20-080425..
	12.2	06	E20	4.2	0.80	5.80°	0.7	1	2	MH20-R020EH20-06L	19.3	30.0	0.9	0.07	23400	MH20-060320..
	12.2	06	E20	4.2	0.80	5.80°	0.7	1	3	MH20-R020EH20-06M	19.3	30.0	0.9	0.07	23400	MH20-060320..
25.0	15.4	08	E25	5.3	1.20	5.70°	0.9	1	2	MH20-R025EH25-08L	24.2	35.0	2.0	0.12	20900	MH20-080425..
	15.4	08	E25	5.3	1.20	5.70°	0.9	1	3	MH20-R025EH25-08M	24.2	35.0	2.0	0.12	20900	MH20-080425..
	17.2	06	E25	4.2	0.80	3.70°	0.7	1	3	MH20-R025EH25-06M	24.2	35.0	0.9	0.13	20900	MH20-060320..
	17.2	06	E25	4.2	0.80	3.70°	0.7	1	4	MH20-R025EH25-06H	24.2	35.0	0.9	0.13	20900	MH20-060320..
32.0	25.4	08	E25	5.3	1.20	3.60°	0.9	1	3	MH20-R032EH25-08L	24.2	35.0	2.0	0.15	18500	MH20-080425..
	25.4	08	E25	5.3	1.20	3.60°	0.9	1	4	MH20-R032EH25-08M	24.2	35.0	2.0	0.14	18500	MH20-080425..

Inch version

											Dimensions, inch					
DCX	DC	SSC	CZC _{MS}	APMX _{EFW}	APMX _{FFW}	RMPX	AZ	CNSC		Ordering code	DCON _{MS}	LF			RPMX	MIID
.625	.318	06	E16	.209	.047	10.10°	.035	1	2	MH20-AR016EH16-06L	.610	1.063	.6	0.13	26300	MH20-060320..
.750	.443	06	E20	.165	.031	6.50°	.028	1	2	MH20-AR019EH20-06L	.728	1.181	.6	0.19	24000	MH20-060320..
	.443	06	E20	.165	.031	6.50°	.028	1	3	MH20-AR019EH20-06M	.728	1.181	.6	0.19	24000	MH20-060320..
1.000	.622	08	E25	.209	.047	5.50°	.035	1	2	MH20-AR025EH25-08L	.965	1.378	1.4	0.33	20700	MH20-080425..
	.622	08	E25	.209	.047	5.50°	.035	1	3	MH20-AR025EH25-08M	.965	1.378	1.4	0.32	20700	MH20-080425..
	.693	06	E25	.165	.031	3.60°	.028	1	3	MH20-AR025EH25-06M	.965	1.378	.6	0.34	20700	MH20-060320..
	.693	06	E25	.165	.031	3.60°	.028	1	4	MH20-AR025EH25-06H	.965	1.378	.6	0.33	20700	MH20-060320..
1.250	.872	08	E25	.209	.031	3.60°	.035	1	3	MH20-AR032EH25-08L	.965	1.378	1.4	0.40	18600	MH20-080425..
	.872	08	E25	.209	.047	3.60°	.035	1	4	MH20-AR032EH25-08M	.965	1.378	1.4	0.39	18600	MH20-080425..

	Spare parts
SSC	Insert screw
06	5513 020-48
08	5513 020-64



CoroMill® MH20 insert for milling

KRINS 15°

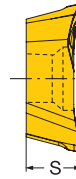
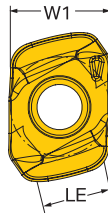
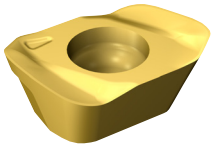

	SSC	REEQ	Ordering code	P		M						S			H		Dimensions, mm, inch			
				1130	4340	1040	1130	2040	4340	S30T	S40T	1130	2040	S30T	S40T	1010	1130	W1	LE	S
Medium	L30	06	2.0	MH20-060320E-L30		★		☆		☆	☆		☆	★	☆		6.4	4.5	3.42	
		.079															.252	.177	.135	
	M20	06	2.0	MH20-060320M-M20	☆	★		☆	☆				☆			★	☆	6.4	4.5	3.42
		.079																.252	.177	.135
	M50	06	2.0	MH20-060320M-M50	☆	★		☆	☆				☆				☆	6.4	4.5	3.42
		.079																.252	.177	.135
L30	08	2.5	MH20-080425E-L30			★		☆	☆	☆		☆	★	☆			8.5	5.9	4.03	
	.098																.335	.232	.159	
M20	08	2.5	MH20-080425M-M20	☆	★		☆	☆				☆			★	☆	8.5	5.9	4.03	
	.098																.335	.232	.159	
M50	08	2.5	MH20-080425M-M50	☆	★		☆	☆				☆				☆	8.5	5.9	4.03	
	.098																.335	.232	.159	



55



86

Drilling

Indexable insert drills

CoroDrill® DS20 59

Solid drills

CoroDrill® 462 60-71
CoroDrill® 862 72-79

For complete assortment, see www.sandvik.coromant.com

B

C

D

E

CoroDrill® DS20 indexable insert drill

Modular drill interface

Internal coolant supply

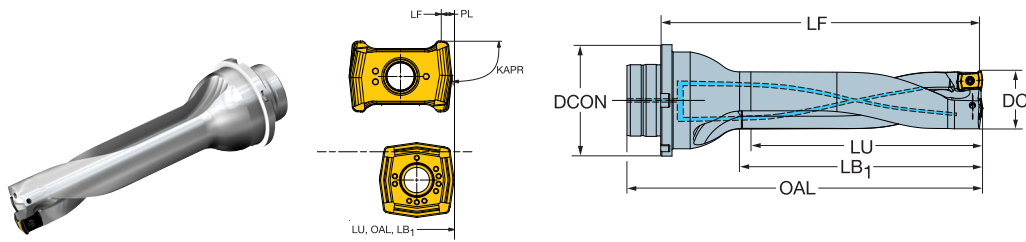

								Dimensions, mm									
DC	SSC	LU	CZC _{MS}	ADJLX	TCHAL	TCHAU	Ordering code	DCON _{MS}	LF	OAL	LB ₁	PL	KAPR	BAR	NM	KG	RPMX
41.00	06P	165.27	MDI-40	3.73	0.00	0.35	DS20-D4100DM40-04	40.00	210.72	227.00	169.00	1.27	81°	10	3.0	1.547	9000
	06C	288.27	MDI-40	3.73	-0.10	0.50	DS20-D4100DM40-07	40.00	333.72	350.00	292.00	1.27	81°	10	3.0	2.179	3000
41.27	06C	166.37	MDI-40	3.65	0.00	0.35	DS20-D4128DM40-04	40.00	210.88	227.16	169.31	1.27	81°	10	3.0	1.559	9000
	06P	290.20	MDI-40	3.65	-0.10	0.50	DS20-D4128DM40-07	40.00	334.71	350.99	293.14	1.27	81°	10	3.0	2.205	3000
42.00	06P	169.27	MDI-40	3.46	0.00	0.35	DS20-D4200DM40-04	40.00	216.72	233.00	173.00	1.27	81°	10	3.0	1.656	8000
	06C	295.27	MDI-40	3.46	-0.10	0.50	DS20-D4200DM40-07	40.00	340.72	357.00	299.00	1.27	81°	10	3.0	2.300	2000
42.84	06C	172.67	MDI-40	3.23	0.00	0.35	DS20-D4285DM40-04	40.00	219.06	235.34	175.61	1.27	81°	10	3.0	1.710	8000
	06P	301.22	MDI-40	3.23	-0.10	0.50	DS20-D4285DM40-07	40.00	347.54	363.81	304.16	1.27	81°	10	3.0	2.434	2000
43.00	06P	173.27	MDI-40	3.19	0.00	0.35	DS20-D4300DM40-04	40.00	220.72	237.00	177.00	1.27	81°	10	3.0	1.731	8000
	06C	302.27	MDI-40	3.19	-0.10	0.50	DS20-D4300DM40-07	40.00	347.72	364.00	306.00	1.27	81°	10	3.0	2.427	2000
44.00	06C	177.27	MDI-50	2.92	0.00	0.35	DS20-D4400DM50-04	50.00	226.72	246.00	181.00	1.27	81°	10	3.0	2.046	8000
	06P	309.27	MDI-50	2.92	-0.10	0.50	DS20-D4400DM50-07	50.00	358.72	378.00	313.00	1.27	81°	10	3.0	2.835	2000
44.45	06C	179.07	MDI-50	2.79	0.00	0.35	DS20-D4445DM50-04	50.00	226.96	246.24	182.01	1.27	81°	10	3.0	2.059	8000
	06C	312.42	MDI-50	2.79	-0.10	0.50	DS20-D4445DM50-07	50.00	360.31	379.59	315.36	1.27	81°	10	3.0	2.874	2000
45.00	06P	181.27	MDI-50	2.65	0.00	0.35	DS20-D4500DM50-04	50.00	230.72	250.00	185.00	1.27	81°	10	3.0	2.130	8000
	06C	316.27	MDI-50	2.65	-0.10	0.50	DS20-D4500DM50-07	50.00	365.72	385.00	320.00	1.27	81°	10	3.0	2.982	2000
46.00	06P	185.27	MDI-50	2.38	0.00	0.35	DS20-D4600DM50-04	50.00	234.72	254.00	189.00	1.27	81°	10	3.0	2.215	8000
47.00	06P	189.27	MDI-50	2.11	0.00	0.35	DS20-D4700DM50-04	50.00	238.72	258.00	193.00	1.27	81°	10	3.0	2.304	8000
47.62	06P	191.77	MDI-50	1.94	0.00	0.35	DS20-D4763DM50-04	50.00	239.43	258.71	194.71	1.27	81°	10	3.0	2.335	7000
48.00	06C	193.27	MDI-50	1.84	0.00	0.35	DS20-D4800DM50-04	50.00	241.72	261.00	197.00	1.27	81°	10	3.0	2.375	7000
49.00	06P	197.27	MDI-50	1.57	0.00	0.35	DS20-D4900DM50-04	50.00	245.72	265.00	201.00	1.27	81°	10	3.0	2.300	7000
50.00	06C	201.27	MDI-50	1.30	0.00	0.35	DS20-D5000DM50-04	50.00	249.72	269.00	205.00	1.27	81°	10	3.0	2.571	7000
50.80	06P	204.47	MDI-50	1.08	0.00	0.35	DS20-D5080DM50-04	50.00	251.88	271.16	207.41	1.27	81°	10	3.0	2.598	7000
51.00	06C	205.27	MDI-50	1.03	0.00	0.35	DS20-D5100DM50-04	50.00	253.72	273.00	209.00	1.27	81°	10	3.0	2.675	7000
52.00	06P	209.27	MDI-50	0.76	0.00	0.35	DS20-D5200DM50-04	50.00	257.72	277.00	213.00	1.27	81°	10	3.0	2.784	7000
53.00	07P	213.58	MDI-50	4.21	0.00	0.35	DS20-D5300DM50-04	50.00	261.41	281.00	217.00	1.58	81°	10	3.0	2.790	7000
53.97	07C	217.48	MDI-50	3.92	0.00	0.35	DS20-D5398DM50-04	50.00	264.32	283.91	220.42	1.58	81°	10	3.0	2.887	7000
54.00	07C	217.58	MDI-50	3.92	0.00	0.35	DS20-D5400DM50-04	50.00	265.41	285.00	221.00	1.58	81°	10	3.0	2.904	7000
55.00	07C	221.58	MDI-50	3.63	0.00	0.35	DS20-D5500DM50-04	50.00	269.41	289.00	225.00	1.58	81°	10	3.0	3.025	6000
56.00	07P	225.58	MDI-50	3.34	0.00	0.35	DS20-D5600DM50-04	50.00	273.41	293.00	229.00	1.58	81°	10	3.0	3.157	6000
57.00	07C	229.58	MDI-50	3.05	0.00	0.35	DS20-D5700DM50-04	50.00	277.41	297.00	233.00	1.58	81°	10	3.0	3.286	6000
57.15	07P	230.18	MDI-50	3.00	0.00	0.35	DS20-D5715DM50-04	50.00	276.76	296.35	233.12	1.58	81°	10	3.0	3.285	6000
58.00	07P	233.58	MDI-50	2.76	0.00	0.35	DS20-D5800DM50-04	50.00	281.41	301.00	237.00	1.58	81°	10	3.0	3.362	6000
59.00	07C	237.58	MDI-50	2.47	0.00	0.35	DS20-D5900DM50-04	50.00	285.41	305.00	241.00	1.58	81°	10	3.0	3.497	6000



CoroDrill® 462-XM solid carbide micro drill

Uncoated (6xD)

External coolant supply

TCHA JS7
SIG 130°

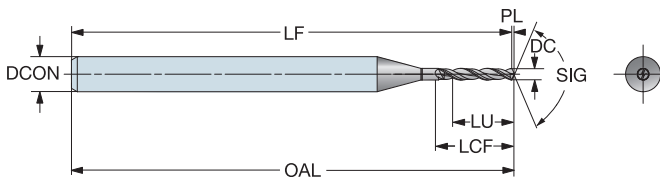
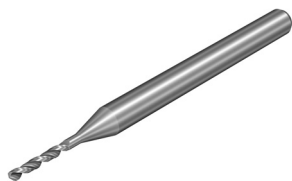

DC	DC*	LU	LU*	ULDR	CZG _{MIS}	Ordering code	P M K N S O					Dimensions, mm, inch										
							H10F	H10F	H10F	H10F	H10F	H10F	DCON _{MIS}	DCON _{MIS} *	OAL	OAL*	LF	LF*	LCF	LCF*	PL	PL*
0.03	.001	0.3	.010	8	3	462.1-0030-002A0-XM	☆	☆	☆	☆	☆	3.0	.118	38	1.496	38.0	1.496	0.3	.014	0.0	.000	
0.04	.002	0.3	.012	7	3	462.1-0040-003A0-XM	☆	☆	☆	☆	☆	3.0	.118	38	1.496	38.0	1.496	0.4	.016	0.0	.000	
0.05	.002	0.4	.014	7	3	462.1-0050-003A0-XM	☆	☆	☆	☆	☆	3.0	.118	38	1.496	38.0	1.496	0.4	.018	0.0	.000	
0.06	.002	0.4	.016	6	3	462.1-0060-004A0-XM	☆	☆	☆	☆	☆	3.0	.118	38	1.496	38.0	1.496	0.5	.020	0.0	.001	
0.07	.003	0.5	.018	6	3	462.1-0070-004A0-XM	☆	☆	☆	☆	☆	3.0	.118	38	1.496	38.0	1.496	0.6	.024	0.0	.001	
0.08	.003	0.5	.020	6	3	462.1-0080-005A0-XM	☆	☆	☆	☆	☆	3.0	.118	38	1.496	38.0	1.496	0.7	.028	0.0	.001	
0.09	.004	0.5	.020	5	3	462.1-0090-005A0-XM	☆	☆	☆	☆	☆	3.0	.118	38	1.496	38.0	1.496	0.7	.028	0.0	.001	
0.10	.004	0.5	.020	5	3	462.1-0100-005A0-XM	☆	☆	☆	☆	☆	3.0	.118	38	1.496	38.0	1.496	0.7	.028	0.0	.001	
0.11	.004	0.5	.020	4	3	462.1-0110-005A0-XM	☆	☆	☆	☆	☆	3.0	.118	38	1.496	38.0	1.496	0.7	.028	0.0	.001	
0.12	.005	0.5	.020	4	3	462.1-0120-005A0-XM	☆	☆	☆	☆	☆	3.0	.118	38	1.496	38.0	1.496	0.7	.028	0.0	.001	
0.13	.005	0.8	.031	6	3	462.1-0130-008A0-XM	☆	☆	☆	☆	☆	3.0	.118	38	1.496	38.0	1.496	1.0	.039	0.0	.001	
0.14	.006	0.8	.031	5	3	462.1-0140-008A0-XM	☆	☆	☆	☆	☆	3.0	.118	38	1.496	38.0	1.496	1.0	.039	0.0	.001	
0.15	.006	0.8	.031	5	3	462.1-0150-008A0-XM	☆	☆	☆	☆	☆	3.0	.118	38	1.496	38.0	1.496	1.0	.039	0.0	.001	
0.16	.006	1.1	.043	6	3	462.1-0160-011A0-XM	☆	☆	☆	☆	☆	3.0	.118	38	1.496	38.0	1.494	1.4	.055	0.0	.001	
0.17	.007	1.1	.043	6	3	462.1-0170-011A0-XM	☆	☆	☆	☆	☆	3.0	.118	38	1.496	38.0	1.494	1.4	.055	0.0	.002	
0.18	.007	1.1	.043	6	3	462.1-0180-011A0-XM	☆	☆	☆	☆	☆	3.0	.118	38	1.496	38.0	1.494	1.4	.055	0.0	.002	
0.19	.007	1.1	.043	5	3	462.1-0190-011A0-XM	☆	☆	☆	☆	☆	3.0	.118	38	1.496	38.0	1.494	1.4	.055	0.0	.002	
0.20	.008	1.5	.059	7	3	462.1-0200-015A0-XM	☆	☆	☆	☆	☆	3.0	.118	38	1.496	38.0	1.494	1.8	.071	0.0	.002	
0.21	.008	1.5	.059	7	3	462.1-0210-015A0-XM	☆	☆	☆	☆	☆	3.0	.118	38	1.496	38.0	1.494	1.8	.071	0.0	.002	
0.22	.009	1.5	.059	6	3	462.1-0220-015A0-XM	☆	☆	☆	☆	☆	3.0	.118	38	1.496	38.0	1.494	1.8	.071	0.1	.002	
0.23	.009	1.5	.059	6	3	462.1-0230-015A0-XM	☆	☆	☆	☆	☆	3.0	.118	38	1.496	38.0	1.494	1.8	.071	0.1	.002	
0.24	.009	1.5	.059	6	3	462.1-0240-015A0-XM	☆	☆	☆	☆	☆	3.0	.118	38	1.496	37.9	1.494	1.8	.071	0.1	.002	
0.25	.010	1.9	.075	7	3	462.1-0250-019A0-XM	☆	☆	☆	☆	☆	3.0	.118	38	1.496	37.9	1.494	2.2	.087	0.1	.002	
0.26	.010	1.9	.075	7	3	462.1-0260-019A0-XM	☆	☆	☆	☆	☆	3.0	.118	38	1.496	37.9	1.494	2.2	.087	0.1	.002	
0.27	.011	1.9	.075	7	3	462.1-0270-019A0-XM	☆	☆	☆	☆	☆	3.0	.118	38	1.496	37.9	1.494	2.2	.087	0.1	.002	
0.28	.011	1.9	.075	6	3	462.1-0280-019A0-XM	☆	☆	☆	☆	☆	3.0	.118	38	1.496	37.9	1.493	2.2	.087	0.1	.003	
0.29	.011	1.9	.075	6	3	462.1-0290-019A0-XM	☆	☆	☆	☆	☆	3.0	.118	38	1.496	37.9	1.493	2.2	.087	0.1	.003	
0.30	.012	1.8	.071	6	3	462.1-0300-018A0-XM	☆	☆	☆	☆	☆	3.0	.118	38	1.496	37.9	1.493	2.4	.094	0.1	.003	
0.31	.012	1.8	.071	5	3	462.1-0310-018A0-XM	☆	☆	☆	☆	☆	3.0	.118	38	1.496	37.9	1.493	2.4	.094	0.1	.003	
0.32	.013	1.8	.071	5	3	462.1-0320-018A0-XM	☆	☆	☆	☆	☆	3.0	.118	38	1.496	37.9	1.493	2.4	.094	0.1	.003	
0.33	.013	1.8	.071	5	3	462.1-0330-018A0-XM	☆	☆	☆	☆	☆	3.0	.118	38	1.496	37.9	1.493	2.4	.094	0.1	.003	
0.34	.013	1.8	.071	5	3	462.1-0340-018A0-XM	☆	☆	☆	☆	☆	3.0	.118	38	1.496	37.9	1.493	2.4	.094	0.1	.003	
0.35	.014	2.2	.087	6	3	462.1-0350-022A0-XM	☆	☆	☆	☆	☆	3.0	.118	38	1.496	37.9	1.493	2.8	.110	0.1	.003	
0.36	.014	2.2	.087	6	3	462.1-0360-022A0-XM	☆	☆	☆	☆	☆	3.0	.118	38	1.496	37.9	1.493	2.8	.110	0.1	.003	
0.37	.015	2.2	.087	5	3	462.1-0370-022A0-XM	☆	☆	☆	☆	☆	3.0	.118	38	1.496	37.9	1.493	2.8	.110	0.1	.003	
0.38	.015	2.2	.087	5	3	462.1-0380-022A0-XM	☆	☆	☆	☆	☆	3.0	.118	38	1.496	37.9	1.493	2.8	.110	0.1	.003	
0.39	.015	2.7	.106	6	3	462.1-0390-027A0-XM	☆	☆	☆	☆	☆	3.0	.118	38	1.496	37.9	1.493	3.6	.142	0.1	.004	
0.40	.016	2.7	.106	6	3	462.1-0400-027A0-XM	☆	☆	☆	☆	☆	3.0	.118	38	1.496	37.9	1.493	3.6	.142	0.1	.004	
0.41	.016	2.7	.106	6	3	462.1-0410-027A0-XM	☆	☆	☆	☆	☆	3.0	.118	38	1.496	37.9	1.492	3.6	.142	0.1	.004	
0.42	.017	2.7	.106	6	3	462.1-0420-027A0-XM	☆	☆	☆	☆	☆	3.0	.118	38	1.496	37.9	1.492	3.6	.142	0.1	.004	
0.43	.017	2.7	.106	6	3	462.1-0430-027A0-XM	☆	☆	☆	☆	☆	3.0	.118	38	1.496	37.9	1.492	3.6	.142	0.1	.004	
0.44	.017	2.7	.106	6	3	462.1-0440-027A0-XM	☆	☆	☆	☆	☆	3.0	.118	38	1.496	37.9	1.492	3.6	.142	0.1	.004	
0.45	.018	2.7	.106	6	3	462.1-0450-027A0-XM	☆	☆	☆	☆	☆	3.0	.118	38	1.496	37.9	1.492	3.6	.142	0.1	.004	
0.46	.018	2.7	.106	5	3	462.1-0460-027A0-XM	☆	☆	☆	☆	☆	3.0	.118	38	1.496	37.9	1.492	3.6	.142	0.1	.004	
0.47	.019	2.7	.106	5	3	462.1-0470-027A0-XM	☆	☆	☆	☆	☆	3.0	.118	38	1.496	37.9	1.492	3.6	.142	0.1	.004	
0.48	.019	2.7	.106	5	3	462.1-0480-027A0-XM	☆	☆	☆	☆	☆	3.0	.118	38	1.496	37.9	1.492	3.6	.142	0.1	.004	
0.49	.019	3.2	.126	6	3	462.1-0490-032A0-XM	☆	☆	☆	☆	☆	3.0	.118	38	1.496	37.9	1.492	4.0	.157	0.1	.004	
0.50	.020	3.2	.126	6	3	462.1-0500-032A0-XM	☆	☆	☆	☆	☆	3.0	.118	38	1.496	37.9	1.491	4.0	.157	0.1	.005	
0.51	.020	3.2	.126	6	3	462.1-0510-032A0-XM	☆	☆	☆	☆	☆	3.0	.118	38	1.496	37.9	1.491	4.0	.157	0.1	.005	
0.52	.020	3.2	.126	6	3	462.1-0520-032A0-XM	☆	☆	☆	☆	☆	3.0	.118	38	1.496	37.9	1.491	4.0	.157	0.1	.005	
0.53	.021	3.2	.126	6	3	462.1-0530-032A0-XM	☆	☆	☆	☆	☆	3.0	.118	38	1.496	37.9	1.491	4.0	.157	0.1	.005	
0.54	.021	3.6	.142	6	3	462.1-0540-036A0-XM	☆	☆	☆	☆	☆	3.0	.118	38	1.496	37.9	1.491	4.5	.177	0.1	.005	



CoroDrill® 462-XM solid carbide micro drill

Uncoated (6xD)

External coolant supply

TCHA JS7
SIG 130°

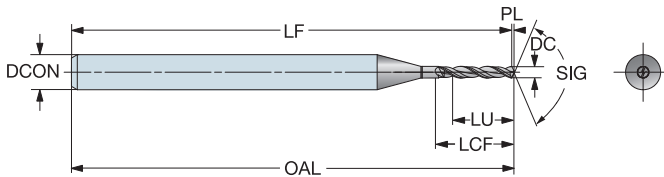

DC	DC*	LU	LU*	ULDR	CZ _{GMS}	Ordering code	P M K N S O						Dimensions, mm, inch									
							H10F		H10F		H10F		DC _{NMS}	DC _{NMS} *	OAL	OAL*	LF	LF*	LCF	LCF*	PL	PL*
							☆	☆	☆	☆	☆	☆										
1.06	.042	7.3	.287	6	3	462.1-1060-073A0-XM	☆	☆	☆	☆	☆	☆	3.0	.118	38	1.496	37.8	1.486	9.0	.354	0.2	.010
1.07	.042	7.3	.287	6	3	462.1-1070-073A0-XM	☆	☆	☆	☆	☆	☆	3.0	.118	38	1.496	37.8	1.486	9.0	.354	0.2	.010
1.08	.043	7.3	.287	6	3	462.1-1080-073A0-XM	☆	☆	☆	☆	☆	☆	3.0	.118	38	1.496	37.8	1.486	9.0	.354	0.3	.010
1.09	.043	7.3	.287	6	3	462.1-1090-073A0-XM	☆	☆	☆	☆	☆	☆	3.0	.118	38	1.496	37.8	1.486	9.0	.354	0.3	.010
1.10	.043	7.3	.287	6	3	462.1-1100-073A0-XM	☆	☆	☆	☆	☆	☆	3.0	.118	38	1.496	37.7	1.486	9.0	.354	0.3	.010
1.11	.044	7.3	.287	6	3	462.1-1110-073A0-XM	☆	☆	☆	☆	☆	☆	3.0	.118	38	1.496	37.7	1.486	9.0	.354	0.3	.010
1.12	.044	7.3	.287	6	3	462.1-1120-073A0-XM	☆	☆	☆	☆	☆	☆	3.0	.118	38	1.496	37.7	1.486	9.0	.354	0.3	.010
1.13	.044	7.3	.287	6	3	462.1-1130-073A0-XM	☆	☆	☆	☆	☆	☆	3.0	.118	38	1.496	37.7	1.486	9.0	.354	0.3	.010
1.14	.045	7.3	.287	6	3	462.1-1140-073A0-XM	☆	☆	☆	☆	☆	☆	3.0	.118	38	1.496	37.7	1.485	9.0	.354	0.3	.010
1.15	.045	7.3	.287	6	3	462.1-1150-073A0-XM	☆	☆	☆	☆	☆	☆	3.0	.118	38	1.496	37.7	1.485	9.0	.354	0.3	.011
1.16	.046	8.2	.323	7	3	462.1-1160-082A0-XM	☆	☆	☆	☆	☆	☆	3.0	.118	38	1.496	37.7	1.485	10.0	.394	0.3	.011
1.17	.046	8.2	.323	7	3	462.1-1170-082A0-XM	☆	☆	☆	☆	☆	☆	3.0	.118	38	1.496	37.7	1.485	10.0	.394	0.3	.011
1.18	.046	8.2	.323	6	3	462.1-1180-082A0-XM	☆	☆	☆	☆	☆	☆	3.0	.118	38	1.496	37.7	1.485	10.0	.394	0.3	.011
1.19	.047	8.2	.323	6	3	462.1-1190-082A0-XM	☆	☆	☆	☆	☆	☆	3.0	.118	38	1.496	37.7	1.485	10.0	.394	0.3	.011
1.20	.047	8.2	.323	6	3	462.1-1200-082A0-XM	☆	☆	☆	☆	☆	☆	3.0	.118	38	1.496	37.7	1.485	10.0	.394	0.3	.011
1.21	.048	8.2	.323	6	3	462.1-1210-082A0-XM	☆	☆	☆	☆	☆	☆	3.0	.118	38	1.496	37.7	1.485	10.0	.394	0.3	.011
1.22	.048	8.2	.323	6	3	462.1-1220-082A0-XM	☆	☆	☆	☆	☆	☆	3.0	.118	38	1.496	37.7	1.485	10.0	.394	0.3	.011
1.23	.048	8.2	.323	6	3	462.1-1230-082A0-XM	☆	☆	☆	☆	☆	☆	3.0	.118	38	1.496	37.7	1.485	10.0	.394	0.3	.011
1.24	.049	8.2	.323	6	3	462.1-1240-082A0-XM	☆	☆	☆	☆	☆	☆	3.0	.118	38	1.496	37.7	1.485	10.0	.394	0.3	.011
1.25	.049	8.2	.323	6	3	462.1-1250-082A0-XM	☆	☆	☆	☆	☆	☆	3.0	.118	38	1.496	37.7	1.485	10.0	.394	0.3	.011
1.26	.050	8.2	.323	6	3	462.1-1260-082A0-XM	☆	☆	☆	☆	☆	☆	3.0	.118	38	1.496	37.7	1.485	10.0	.394	0.3	.012
1.27	.050	8.2	.323	6	3	462.1-1270-082A0-XM	☆	☆	☆	☆	☆	☆	3.0	.118	38	1.496	37.7	1.484	10.0	.394	0.3	.012
1.28	.050	8.2	.323	6	3	462.1-1280-082A0-XM	☆	☆	☆	☆	☆	☆	3.0	.118	38	1.496	37.7	1.484	10.0	.394	0.3	.012
1.29	.051	8.2	.323	6	3	462.1-1290-082A0-XM	☆	☆	☆	☆	☆	☆	3.0	.118	38	1.496	37.7	1.484	10.0	.394	0.3	.012
1.30	.051	8.2	.323	6	3	462.1-1300-082A0-XM	☆	☆	☆	☆	☆	☆	3.0	.118	38	1.496	37.7	1.484	10.0	.394	0.3	.012
1.31	.052	9.2	.362	7	3	462.1-1310-092A0-XM	☆	☆	☆	☆	☆	☆	3.0	.118	38	1.496	37.7	1.484	11.2	.441	0.3	.012
1.32	.052	9.2	.362	6	3	462.1-1320-092A0-XM	☆	☆	☆	☆	☆	☆	3.0	.118	38	1.496	37.7	1.484	11.2	.441	0.3	.012
1.33	.052	9.2	.362	6	3	462.1-1330-092A0-XM	☆	☆	☆	☆	☆	☆	3.0	.118	38	1.496	37.7	1.484	11.2	.441	0.3	.012
1.34	.053	9.2	.362	6	3	462.1-1340-092A0-XM	☆	☆	☆	☆	☆	☆	3.0	.118	38	1.496	37.7	1.484	11.2	.441	0.3	.012
1.35	.053	9.2	.362	6	3	462.1-1350-092A0-XM	☆	☆	☆	☆	☆	☆	3.0	.118	38	1.496	37.7	1.484	11.2	.441	0.3	.012
1.36	.054	9.2	.362	6	3	462.1-1360-092A0-XM	☆	☆	☆	☆	☆	☆	3.0	.118	38	1.496	37.7	1.483	11.2	.441	0.3	.012
1.37	.054	9.2	.362	6	3	462.1-1370-092A0-XM	☆	☆	☆	☆	☆	☆	3.0	.118	38	1.496	37.7	1.483	11.2	.441	0.3	.013
1.38	.054	9.2	.362	6	3	462.1-1380-092A0-XM	☆	☆	☆	☆	☆	☆	3.0	.118	38	1.496	37.7	1.483	11.2	.441	0.3	.013
1.39	.055	9.2	.362	6	3	462.1-1390-092A0-XM	☆	☆	☆	☆	☆	☆	3.0	.118	38	1.496	37.7	1.483	11.2	.441	0.3	.013
1.40	.055	9.2	.362	6	3	462.1-1400-092A0-XM	☆	☆	☆	☆	☆	☆	3.0	.118	38	1.496	37.7	1.483	11.2	.441	0.3	.013
1.41	.056	9.2	.362	6	3	462.1-1410-092A0-XM	☆	☆	☆	☆	☆	☆	3.0	.118	38	1.496	37.7	1.483	11.2	.441	0.3	.013
1.42	.056	9.2	.362	6	3	462.1-1420-092A0-XM	☆	☆	☆	☆	☆	☆	3.0	.118	38	1.496	37.7	1.483	11.2	.441	0.3	.013
1.43	.056	9.2	.362	6	3	462.1-1430-092A0-XM	☆	☆	☆	☆	☆	☆	3.0	.118	38	1.496	37.7	1.483	11.2	.441	0.3	.013
1.44	.057	9.2	.362	6	3	462.1-1440-092A0-XM	☆	☆	☆	☆	☆	☆	3.0	.118	38	1.496	37.7	1.483	11.2	.441	0.3	.013
1.45	.057	9.2	.362	6	3	462.1-1450-092A0-XM	☆	☆	☆	☆	☆	☆	3.0	.118	38	1.496	37.7	1.483	11.2	.441	0.3	.013
1.46	.057	9.2	.362	6	3	462.1-1460-092A0-XM	☆	☆	☆	☆	☆	☆	3.0	.118	38	1.496	37.7	1.483	11.2	.441	0.3	.013
1.47	.058	9.2	.362	6	3	462.1-1470-092A0-XM	☆	☆	☆	☆	☆	☆	3.0	.118	38	1.496	37.7	1.483	11.2	.441	0.3	.013
1.48	.058	9.2	.362	6	3	462.1-1480-092A0-XM	☆	☆	☆	☆	☆	☆	3.0	.118	38	1.496	37.7	1.482	11.2	.441	0.3	.014
1.49	.059	9.2	.362	6	3	462.1-1490-092A0-XM	☆	☆	☆	☆	☆	☆	3.0	.118	38	1.496	37.7	1.482	11.2	.441	0.3	.014
1.50	.059	9.2	.362	6	3	462.1-1500-092A0-XM	☆	☆	☆	☆	☆	☆	3.0	.118	38	1.496	37.7	1.482	11.2	.441	0.3	.014
1.51	.059	11.2	.441	7	3	462.1-1510-112A0-XM	☆	☆	☆	☆	☆	☆	3.0	.118	38	1.496	37.7	1.482	13.4	.528	0.4	.014
1.52	.060	11.2	.441	7	3	462.1-1520-112A0-XM	☆	☆	☆	☆	☆	☆	3.0	.118	38	1.496	37.7	1.482	13.4	.528	0.4	.014
1.53	.060	11.2	.441	7	3	462.1-1530-112A0-XM	☆	☆	☆	☆	☆	☆	3.0	.118	38	1.496	37.6	1.482	13.4	.528	0.4	.014
1.54	.061	11.2	.441	7	3	462.1-1540-112A0-XM	☆	☆	☆	☆	☆	☆	3.0	.118	38	1.496	37.6	1.482	13.4	.528	0.4	.014
1.55	.061	11.2	.441	7	3	462.1-1550-112A0-XM	☆	☆	☆	☆	☆	☆	3.0	.118	38	1.496	37.6	1.482	13.4	.528	0.4	.014
1.56	.061	11.2	.441	7	3	462.1-1560-112A0-XM	☆	☆	☆	☆	☆	☆	3.0	.118	38	1.496	37.6	1.482	13.4	.528	0.4	.014



CoroDrill® 462-XM solid carbide micro drill

Uncoated (6xD)

External coolant supply

TCHA JS7
SIG 130°

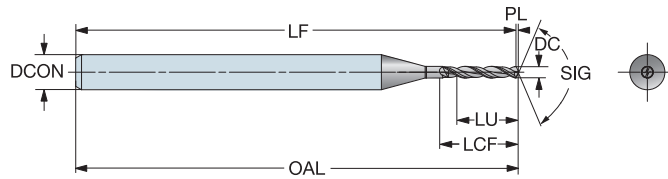
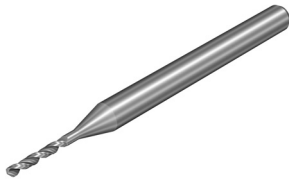

										Dimensions, mm, inch																
										P	M	K	N	S	O											
										H10F	H10F	H10F	H10F	H10F	H10F											
DC	DC*	LU	LU*	ULDR	CZC _{MS}	Ordering code											DCON _{MS}	DCON _{MS} *	OAL	OAL*	LF	LF*	LCF	LCF*	PL	PL*
2.58	.102	14.0	.551	5	3	462.1-2580-140A0-XM	☆	☆	☆	☆	☆	☆	☆	☆	3.0	.118	38	1.496	37.4	1.472	17.0	.669	0.6	.024		
2.59	.102	14.0	.551	5	3	462.1-2590-140A0-XM	☆	☆	☆	☆	☆	☆	☆	☆	3.0	.118	38	1.496	37.4	1.472	17.0	.669	0.6	.024		
2.60	.102	14.0	.551	5	3	462.1-2600-140A0-XM	☆	☆	☆	☆	☆	☆	☆	☆	3.0	.118	38	1.496	37.4	1.472	17.0	.669	0.6	.024		
2.61	.103	14.0	.551	5	3	462.1-2610-140A0-XM	☆	☆	☆	☆	☆	☆	☆	☆	3.0	.118	38	1.496	37.4	1.472	17.0	.669	0.6	.024		
2.62	.103	14.0	.551	5	3	462.1-2620-140A0-XM	☆	☆	☆	☆	☆	☆	☆	☆	3.0	.118	38	1.496	37.4	1.472	17.0	.669	0.6	.024		
2.63	.104	14.0	.551	5	3	462.1-2630-140A0-XM	☆	☆	☆	☆	☆	☆	☆	☆	3.0	.118	38	1.496	37.4	1.472	17.0	.669	0.6	.024		
2.64	.104	14.0	.551	5	3	462.1-2640-140A0-XM	☆	☆	☆	☆	☆	☆	☆	☆	3.0	.118	38	1.496	37.4	1.472	17.0	.669	0.6	.024		
2.65	.104	14.0	.551	5	3	462.1-2650-140A0-XM	☆	☆	☆	☆	☆	☆	☆	☆	3.0	.118	38	1.496	37.4	1.472	17.0	.669	0.6	.024		
2.66	.105	14.0	.551	5	3	462.1-2660-140A0-XM	☆	☆	☆	☆	☆	☆	☆	☆	3.0	.118	38	1.496	37.4	1.472	17.0	.669	0.6	.024		
2.67	.105	14.0	.551	5	3	462.1-2670-140A0-XM	☆	☆	☆	☆	☆	☆	☆	☆	3.0	.118	38	1.496	37.4	1.472	17.0	.669	0.6	.025		
2.68	.106	14.0	.551	5	3	462.1-2680-140A0-XM	☆	☆	☆	☆	☆	☆	☆	☆	3.0	.118	38	1.496	37.4	1.472	17.0	.669	0.6	.025		
2.69	.106	14.0	.551	5	3	462.1-2690-140A0-XM	☆	☆	☆	☆	☆	☆	☆	☆	3.0	.118	38	1.496	37.4	1.471	17.0	.669	0.6	.025		
2.70	.106	14.0	.551	5	3	462.1-2700-140A0-XM	☆	☆	☆	☆	☆	☆	☆	☆	3.0	.118	38	1.496	37.4	1.471	17.0	.669	0.6	.025		
2.71	.107	14.0	.551	5	3	462.1-2710-140A0-XM	☆	☆	☆	☆	☆	☆	☆	☆	3.0	.118	38	1.496	37.4	1.471	17.0	.669	0.6	.025		
2.72	.107	14.0	.551	5	3	462.1-2720-140A0-XM	☆	☆	☆	☆	☆	☆	☆	☆	3.0	.118	38	1.496	37.4	1.471	17.0	.669	0.6	.025		
2.73	.107	14.0	.551	5	3	462.1-2730-140A0-XM	☆	☆	☆	☆	☆	☆	☆	☆	3.0	.118	38	1.496	37.4	1.471	17.0	.669	0.6	.025		
2.74	.108	14.0	.551	5	3	462.1-2740-140A0-XM	☆	☆	☆	☆	☆	☆	☆	☆	3.0	.118	38	1.496	37.4	1.471	17.0	.669	0.6	.025		
2.75	.108	14.0	.551	5	3	462.1-2750-140A0-XM	☆	☆	☆	☆	☆	☆	☆	☆	3.0	.118	38	1.496	37.4	1.471	17.0	.669	0.6	.025		
2.76	.109	14.0	.551	5	3	462.1-2760-140A0-XM	☆	☆	☆	☆	☆	☆	☆	☆	3.0	.118	38	1.496	37.4	1.471	17.0	.669	0.6	.025		
2.77	.109	14.0	.551	5	3	462.1-2770-140A0-XM	☆	☆	☆	☆	☆	☆	☆	☆	3.0	.118	38	1.496	37.4	1.470	17.0	.669	0.6	.025		
2.78	.109	14.0	.551	5	3	462.1-2780-140A0-XM	☆	☆	☆	☆	☆	☆	☆	☆	3.0	.118	38	1.496	37.4	1.470	17.0	.669	0.6	.026		
2.79	.110	14.0	.551	5	3	462.1-2790-140A0-XM	☆	☆	☆	☆	☆	☆	☆	☆	3.0	.118	38	1.496	37.4	1.470	17.0	.669	0.7	.026		
2.80	.110	14.0	.551	5	3	462.1-2800-140A0-XM	☆	☆	☆	☆	☆	☆	☆	☆	3.0	.118	38	1.496	37.4	1.470	17.0	.669	0.7	.026		
2.81	.111	14.0	.551	4	3	462.1-2810-140A0-XM	☆	☆	☆	☆	☆	☆	☆	☆	3.0	.118	38	1.496	37.3	1.470	17.0	.669	0.7	.026		
2.82	.111	14.0	.551	4	3	462.1-2820-140A0-XM	☆	☆	☆	☆	☆	☆	☆	☆	3.0	.118	38	1.496	37.3	1.470	17.0	.669	0.7	.026		
2.83	.111	14.0	.551	4	3	462.1-2830-140A0-XM	☆	☆	☆	☆	☆	☆	☆	☆	3.0	.118	38	1.496	37.3	1.470	17.0	.669	0.7	.026		
2.84	.112	14.0	.551	4	3	462.1-2840-140A0-XM	☆	☆	☆	☆	☆	☆	☆	☆	3.0	.118	38	1.496	37.3	1.470	17.0	.669	0.7	.026		
2.85	.112	14.0	.551	4	3	462.1-2850-140A0-XM	☆	☆	☆	☆	☆	☆	☆	☆	3.0	.118	38	1.496	37.3	1.470	17.0	.669	0.7	.026		
2.86	.113	14.0	.551	4	3	462.1-2860-140A0-XM	☆	☆	☆	☆	☆	☆	☆	☆	3.0	.118	38	1.496	37.3	1.470	17.0	.669	0.7	.026		
2.87	.113	14.0	.551	4	3	462.1-2870-140A0-XM	☆	☆	☆	☆	☆	☆	☆	☆	3.0	.118	38	1.496	37.3	1.470	17.0	.669	0.7	.026		
2.88	.113	14.0	.551	4	3	462.1-2880-140A0-XM	☆	☆	☆	☆	☆	☆	☆	☆	3.0	.118	38	1.496	37.3	1.470	17.0	.669	0.7	.026		
2.89	.114	14.0	.551	4	3	462.1-2890-140A0-XM	☆	☆	☆	☆	☆	☆	☆	☆	3.0	.118	38	1.496	37.3	1.470	17.0	.669	0.7	.027		
2.90	.114	14.0	.551	4	3	462.1-2900-140A0-XM	☆	☆	☆	☆	☆	☆	☆	☆	3.0	.118	38	1.496	37.3	1.469	17.0	.669	0.7	.027		
2.91	.115	14.0	.551	4	3	462.1-2910-140A0-XM	☆	☆	☆	☆	☆	☆	☆	☆	3.0	.118	38	1.496	37.3	1.469	17.0	.669	0.7	.027		
2.92	.115	14.0	.551	4	3	462.1-2920-140A0-XM	☆	☆	☆	☆	☆	☆	☆	☆	3.0	.118	38	1.496	37.3	1.469	17.0	.669	0.7	.027		
2.93	.115	14.0	.551	4	3	462.1-2930-140A0-XM	☆	☆	☆	☆	☆	☆	☆	☆	3.0	.118	38	1.496	37.3	1.469	17.0	.669	0.7	.027		
2.94	.116	14.0	.551	4	3	462.1-2940-140A0-XM	☆	☆	☆	☆	☆	☆	☆	☆	3.0	.118	38	1.496	37.3	1.469	17.0	.669	0.7	.027		
2.95	.116	14.0	.551	4	3	462.1-2950-140A0-XM	☆	☆	☆	☆	☆	☆	☆	☆	3.0	.118	38	1.496	37.3	1.469	17.0	.669	0.7	.027		
2.96	.117	14.0	.551	4	3	462.1-2960-140A0-XM	☆	☆	☆	☆	☆	☆	☆	☆	3.0	.118	38	1.496	37.3	1.469	17.0	.669	0.7	.027		
2.97	.117	14.0	.551	4	3	462.1-2970-140A0-XM	☆	☆	☆	☆	☆	☆	☆	☆	3.0	.118	38	1.496	37.3	1.469	17.0	.669	0.7	.027		
2.98	.117	14.0	.551	4	3	462.1-2980-140A0-XM	☆	☆	☆	☆	☆	☆	☆	☆	3.0	.118	38	1.496	37.3	1.469	17.0	.669	0.7	.027		
2.99	.118	14.0	.551	4	3	462.1-2990-140A0-XM	☆	☆	☆	☆	☆	☆	☆	☆	3.0	.118	38	1.496	37.3	1.469	17.0	.669	0.7	.027		
3.00	.118	14.0	.551	4	3	462.1-3000-140A0-XM	☆	☆	☆	☆	☆	☆	☆	☆	3.0	.118	38	1.496	37.3	1.469	17.0	.669	0.7	.028		



CoroDrill® 462-XM solid carbide micro drill

Coated (6xD)

External coolant supply

TCHA JS7
SIG 130°

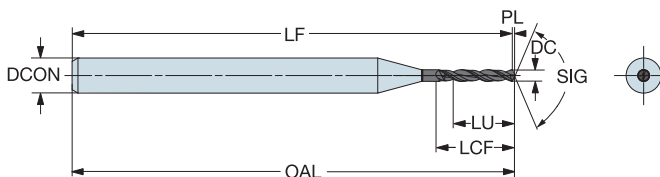
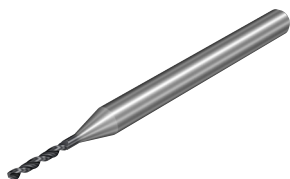

DC	DC*	LU	LU*	ULDR	CZG _{MS}	Ordering code	Material						Dimensions, mm, inch												
							P	M	K	N	S	H	O	DCON _{MS}	DCON _{MS} *	OAL	OAL*	LF	LF*	LCF	LCF*	PL	PL*		
0.20	.008	1.5	.059	7	3	462.1-0200-015A0-XM	*	*	*	*	*	*	*	*	*	3.0	.118	38	1.496	38.0	1.494	1.8	.071	0.0	.002
0.21	.008	1.5	.059	7	3	462.1-0210-015A0-XM	*	*	*	*	*	*	*	*	*	3.0	.118	38	1.496	38.0	1.494	1.8	.071	0.0	.002
0.22	.009	1.5	.059	6	3	462.1-0220-015A0-XM	*	*	*	*	*	*	*	*	*	3.0	.118	38	1.496	38.0	1.494	1.8	.071	0.1	.002
0.23	.009	1.5	.059	6	3	462.1-0230-015A0-XM	*	*	*	*	*	*	*	*	*	3.0	.118	38	1.496	38.0	1.494	1.8	.071	0.1	.002
0.24	.009	1.5	.059	6	3	462.1-0240-015A0-XM	*	*	*	*	*	*	*	*	*	3.0	.118	38	1.496	37.9	1.494	1.8	.071	0.1	.002
0.25	.010	1.9	.075	7	3	462.1-0250-019A0-XM	*	*	*	*	*	*	*	*	*	3.0	.118	38	1.496	37.9	1.494	2.2	.087	0.1	.002
0.26	.010	1.9	.075	7	3	462.1-0260-019A0-XM	*	*	*	*	*	*	*	*	*	3.0	.118	38	1.496	37.9	1.494	2.2	.087	0.1	.002
0.27	.011	1.9	.075	7	3	462.1-0270-019A0-XM	*	*	*	*	*	*	*	*	*	3.0	.118	38	1.496	37.9	1.494	2.2	.087	0.1	.002
0.28	.011	1.9	.075	6	3	462.1-0280-019A0-XM	*	*	*	*	*	*	*	*	*	3.0	.118	38	1.496	37.9	1.493	2.2	.087	0.1	.003
0.29	.011	1.9	.075	6	3	462.1-0290-019A0-XM	*	*	*	*	*	*	*	*	*	3.0	.118	38	1.496	37.9	1.493	2.2	.087	0.1	.003
0.30	.012	1.8	.071	6	3	462.1-0300-018A0-XM	*	*	*	*	*	*	*	*	*	3.0	.118	38	1.496	37.9	1.493	2.4	.094	0.1	.003
0.31	.012	1.8	.071	5	3	462.1-0310-018A0-XM	*	*	*	*	*	*	*	*	*	3.0	.118	38	1.496	37.9	1.493	2.4	.094	0.1	.003
0.32	.013	1.8	.071	5	3	462.1-0320-018A0-XM	*	*	*	*	*	*	*	*	*	3.0	.118	38	1.496	37.9	1.493	2.4	.094	0.1	.003
0.33	.013	1.8	.071	5	3	462.1-0330-018A0-XM	*	*	*	*	*	*	*	*	*	3.0	.118	38	1.496	37.9	1.493	2.4	.094	0.1	.003
0.34	.013	1.8	.071	5	3	462.1-0340-018A0-XM	*	*	*	*	*	*	*	*	*	3.0	.118	38	1.496	37.9	1.493	2.4	.094	0.1	.003
0.35	.014	2.2	.087	6	3	462.1-0350-022A0-XM	*	*	*	*	*	*	*	*	*	3.0	.118	38	1.496	37.9	1.493	2.8	.110	0.1	.003
0.36	.014	2.2	.087	6	3	462.1-0360-022A0-XM	*	*	*	*	*	*	*	*	*	3.0	.118	38	1.496	37.9	1.493	2.8	.110	0.1	.003
0.37	.015	2.2	.087	5	3	462.1-0370-022A0-XM	*	*	*	*	*	*	*	*	*	3.0	.118	38	1.496	37.9	1.493	2.8	.110	0.1	.003
0.38	.015	2.2	.087	5	3	462.1-0380-022A0-XM	*	*	*	*	*	*	*	*	*	3.0	.118	38	1.496	37.9	1.493	2.8	.110	0.1	.003
0.39	.015	2.7	.106	6	3	462.1-0390-027A0-XM	*	*	*	*	*	*	*	*	*	3.0	.118	38	1.496	37.9	1.493	3.6	.142	0.1	.004
0.40	.016	2.7	.106	6	3	462.1-0400-027A0-XM	*	*	*	*	*	*	*	*	*	3.0	.118	38	1.496	37.9	1.493	3.6	.142	0.1	.004
0.41	.016	2.7	.106	6	3	462.1-0410-027A0-XM	*	*	*	*	*	*	*	*	*	3.0	.118	38	1.496	37.9	1.492	3.6	.142	0.1	.004
0.42	.017	2.7	.106	6	3	462.1-0420-027A0-XM	*	*	*	*	*	*	*	*	*	3.0	.118	38	1.496	37.9	1.492	3.6	.142	0.1	.004
0.43	.017	2.7	.106	6	3	462.1-0430-027A0-XM	*	*	*	*	*	*	*	*	*	3.0	.118	38	1.496	37.9	1.492	3.6	.142	0.1	.004
0.44	.017	2.7	.106	6	3	462.1-0440-027A0-XM	*	*	*	*	*	*	*	*	*	3.0	.118	38	1.496	37.9	1.492	3.6	.142	0.1	.004
0.45	.018	2.7	.106	6	3	462.1-0450-027A0-XM	*	*	*	*	*	*	*	*	*	3.0	.118	38	1.496	37.9	1.492	3.6	.142	0.1	.004
0.46	.018	2.7	.106	5	3	462.1-0460-027A0-XM	*	*	*	*	*	*	*	*	*	3.0	.118	38	1.496	37.9	1.492	3.6	.142	0.1	.004
0.47	.019	2.7	.106	5	3	462.1-0470-027A0-XM	*	*	*	*	*	*	*	*	*	3.0	.118	38	1.496	37.9	1.492	3.6	.142	0.1	.004
0.48	.019	2.7	.106	5	3	462.1-0480-027A0-XM	*	*	*	*	*	*	*	*	*	3.0	.118	38	1.496	37.9	1.492	3.6	.142	0.1	.004
0.49	.019	3.2	.126	6	3	462.1-0490-032A0-XM	*	*	*	*	*	*	*	*	*	3.0	.118	38	1.496	37.9	1.492	4.0	.157	0.1	.004
0.50	.020	3.2	.126	6	3	462.1-0500-032A0-XM	*	*	*	*	*	*	*	*	*	3.0	.118	38	1.496	37.9	1.491	4.0	.157	0.1	.005
0.51	.020	3.2	.126	6	3	462.1-0510-032A0-XM	*	*	*	*	*	*	*	*	*	3.0	.118	38	1.496	37.9	1.491	4.0	.157	0.1	.005
0.52	.020	3.2	.126	6	3	462.1-0520-032A0-XM	*	*	*	*	*	*	*	*	*	3.0	.118	38	1.496	37.9	1.491	4.0	.157	0.1	.005
0.53	.021	3.2	.126	6	3	462.1-0530-032A0-XM	*	*	*	*	*	*	*	*	*	3.0	.118	38	1.496	37.9	1.491	4.0	.157	0.1	.005
0.54	.021	3.6	.142	6	3	462.1-0540-036A0-XM	*	*	*	*	*	*	*	*	*	3.0	.118	38	1.496	37.9	1.491	4.5	.177	0.1	.005
0.55	.022	3.6	.142	6	3	462.1-0550-036A0-XM	*	*	*	*	*	*	*	*	*	3.0	.118	38	1.496	37.9	1.491	4.5	.177	0.1	.005
0.56	.022	3.6	.142	6	3	462.1-0560-036A0-XM	*	*	*	*	*	*	*	*	*	3.0	.118	38	1.496	37.9	1.491	4.5	.177	0.1	.005
0.57	.022	3.6	.142	6	3	462.1-0570-036A0-XM	*	*	*	*	*	*	*	*	*	3.0	.118	38	1.496	37.9	1.491	4.5	.177	0.1	.005
0.58	.023	3.6	.142	6	3	462.1-0580-036A0-XM	*	*	*	*	*	*	*	*	*	3.0	.118	38	1.496	37.9	1.491	4.5	.177	0.1	.005
0.59	.023	3.6	.142	6	3	462.1-0590-036A0-XM	*	*	*	*	*	*	*	*	*	3.0	.118	38	1.496	37.9	1.491	4.5	.177	0.1	.005
0.60	.024	3.6	.142	6	3	462.1-0600-036A0-XM	*	*	*	*	*	*	*	*	*	3.0	.118	38	1.496	37.9	1.491	4.5	.177	0.1	.006
0.61	.024	3.9	.154	6	3	462.1-0610-039A0-XM	*	*	*	*	*	*	*	*	*	3.0	.118	38	1.496	37.9	1.491	5.0	.197	0.1	.006
0.62	.024	3.9	.154	6	3	462.1-0620-039A0-XM	*	*	*	*	*	*	*	*	*	3.0	.118	38	1.496	37.9	1.491	5.0	.197	0.1	.006
0.63	.025	3.9	.154	6	3	462.1-0630-039A0-XM	*	*	*	*	*	*	*	*	*	3.0	.118	38	1.496	37.9	1.490	5.0	.197	0.1	.006
0.64	.025	3.9	.154	6	3	462.1-0640-039A0-XM	*	*	*	*	*	*	*	*	*	3.0	.118	38	1.496	37.9	1.490	5.0	.197	0.1	.006
0.65	.026	3.9	.154	6	3	462.1-0650-039A0-XM	*	*	*	*	*	*	*	*	*	3.0	.118	38	1.496	37.9	1.490	5.0	.197	0.2	.006
0.66	.026	3.9	.154	5	3	462.1-0660-039A0-XM	*	*	*	*	*	*	*	*	*	3.0	.118	38	1.496	37.9	1.490	5.0	.197	0.2	.006
0.67	.026	3.9	.154	5	3	462.1-0670-039A0-XM	*	*	*	*	*	*	*	*	*	3.0	.118	38	1.496	37.8	1.490	5.0	.197	0.2	.006
0.68	.027	4.5	.177	6	3	462.1-0680-045A0-XM	*	*	*	*	*	*	*	*	*	3.0	.118	38	1.496	37.8	1.490	5.6	.220	0.2	.006
0.69	.027	4.5	.177	6	3	462.1-0690-045A0-XM	*	*	*	*	*	*	*	*	*	3.0	.118	38	1.496	37.8	1.490	5.6	.220	0.2	.006



CoroDrill® 462-XM solid carbide micro drill

Coated (6xD)

External coolant supply

TCHA JS7
SIG 130°

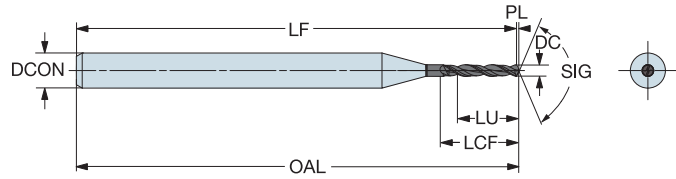

DC	DC*	LU	LU*	ULDR	CZC _{MS}	Ordering code	P M K N S H O						Dimensions, mm, inch																	
							P		M		K		N		S		H		O		DCON _{MS}	DCON _{MS} "	OAL	OAL"	LF	LF*	LCF	LCF*	PL	PL"
							XZBM	XZBM	XZBM	XZBM	XZBM	XZBM	XZBM	XZBM	XZBM	XZBM	XZBM	XZBM	XZBM	XZBM										
0.70	.028	4.5	.177	6	3	462.1-0700-045A0-XM	*	*	*	*	*	*	*	*	*	*	3.0	.118	38	1.496	37.8	1.490	5	.220	0.2	.006				
0.71	.028	4.5	.177	6	3	462.1-0710-045A0-XM	*	*	*	*	*	*	*	*	*	*	3.0	.118	38	1.496	37.8	1.489	5	.220	0.2	.007				
0.72	.028	4.5	.177	6	3	462.1-0720-045A0-XM	*	*	*	*	*	*	*	*	*	*	3.0	.118	38	1.496	37.8	1.489	5	.220	0.2	.007				
0.73	.029	4.5	.177	6	3	462.1-0730-045A0-XM	*	*	*	*	*	*	*	*	*	*	3.0	.118	38	1.496	37.8	1.489	5	.220	0.2	.007				
0.74	.029	4.5	.177	6	3	462.1-0740-045A0-XM	*	*	*	*	*	*	*	*	*	*	3.0	.118	38	1.496	37.8	1.489	5	.220	0.2	.007				
0.75	.030	4.5	.177	6	3	462.1-0750-045A0-XM	*	*	*	*	*	*	*	*	*	*	3.0	.118	38	1.496	37.8	1.489	5	.220	0.2	.007				
0.76	.030	5.0	.197	6	3	462.1-0760-050A0-XM	*	*	*	*	*	*	*	*	*	*	3.0	.118	38	1.496	37.8	1.489	6	.248	0.2	.007				
0.77	.030	5.0	.197	6	3	462.1-0770-050A0-XM	*	*	*	*	*	*	*	*	*	*	3.0	.118	38	1.496	37.8	1.489	6	.248	0.2	.007				
0.78	.031	5.0	.197	6	3	462.1-0780-050A0-XM	*	*	*	*	*	*	*	*	*	*	3.0	.118	38	1.496	37.8	1.489	6	.248	0.2	.007				
0.79	.031	5.0	.197	6	3	462.1-0790-050A0-XM	*	*	*	*	*	*	*	*	*	*	3.0	.118	38	1.496	37.8	1.489	6	.248	0.2	.007				
0.80	.031	5.0	.197	6	3	462.1-0800-050A0-XM	*	*	*	*	*	*	*	*	*	*	3.0	.118	38	1.496	37.8	1.489	6	.248	0.2	.007				
0.81	.032	5.0	.197	6	3	462.1-0810-050A0-XM	*	*	*	*	*	*	*	*	*	*	3.0	.118	38	1.496	37.8	1.489	6	.248	0.2	.007				
0.82	.032	5.0	.197	6	3	462.1-0820-050A0-XM	*	*	*	*	*	*	*	*	*	*	3.0	.118	38	1.496	37.8	1.489	6	.248	0.2	.008				
0.83	.033	5.0	.197	6	3	462.1-0830-050A0-XM	*	*	*	*	*	*	*	*	*	*	3.0	.118	38	1.496	37.8	1.489	6	.248	0.2	.008				
0.84	.033	5.0	.197	5	3	462.1-0840-050A0-XM	*	*	*	*	*	*	*	*	*	*	3.0	.118	38	1.496	37.8	1.488	6	.248	0.2	.008				
0.85	.033	5.0	.197	5	3	462.1-0850-050A0-XM	*	*	*	*	*	*	*	*	*	*	3.0	.118	38	1.496	37.8	1.488	6	.248	0.2	.008				
0.86	.034	5.7	.224	6	3	462.1-0860-057A0-XM	*	*	*	*	*	*	*	*	*	*	3.0	.118	38	1.496	37.8	1.488	7	.280	0.2	.008				
0.87	.034	5.7	.224	6	3	462.1-0870-057A0-XM	*	*	*	*	*	*	*	*	*	*	3.0	.118	38	1.496	37.8	1.488	7	.280	0.2	.008				
0.88	.035	5.7	.224	6	3	462.1-0880-057A0-XM	*	*	*	*	*	*	*	*	*	*	3.0	.118	38	1.496	37.8	1.488	7	.280	0.2	.008				
0.89	.035	5.7	.224	6	3	462.1-0890-057A0-XM	*	*	*	*	*	*	*	*	*	*	3.0	.118	38	1.496	37.8	1.488	7	.280	0.2	.008				
0.90	.035	5.7	.224	6	3	462.1-0900-057A0-XM	*	*	*	*	*	*	*	*	*	*	3.0	.118	38	1.496	37.8	1.488	7	.280	0.2	.008				
0.91	.036	5.7	.224	6	3	462.1-0910-057A0-XM	*	*	*	*	*	*	*	*	*	*	3.0	.118	38	1.496	37.8	1.488	7	.280	0.2	.008				
0.92	.036	5.7	.224	6	3	462.1-0920-057A0-XM	*	*	*	*	*	*	*	*	*	*	3.0	.118	38	1.496	37.8	1.488	7	.280	0.2	.008				
0.93	.037	5.7	.224	6	3	462.1-0930-057A0-XM	*	*	*	*	*	*	*	*	*	*	3.0	.118	38	1.496	37.8	1.487	7	.280	0.2	.009				
0.94	.037	5.7	.224	6	3	462.1-0940-057A0-XM	*	*	*	*	*	*	*	*	*	*	3.0	.118	38	1.496	37.8	1.487	7	.280	0.2	.009				
0.95	.037	5.7	.224	6	3	462.1-0950-057A0-XM	*	*	*	*	*	*	*	*	*	*	3.0	.118	38	1.496	37.8	1.487	7	.280	0.2	.009				
0.96	.038	6.5	.256	6	3	462.1-0960-065A0-XM	*	*	*	*	*	*	*	*	*	*	3.0	.118	38	1.496	37.8	1.487	8	.315	0.2	.009				
0.97	.038	6.5	.256	6	3	462.1-0970-065A0-XM	*	*	*	*	*	*	*	*	*	*	3.0	.118	38	1.496	37.8	1.487	8	.315	0.2	.009				
0.98	.039	6.5	.256	6	3	462.1-0980-065A0-XM	*	*	*	*	*	*	*	*	*	*	3.0	.118	38	1.496	37.8	1.487	8	.315	0.2	.009				
0.99	.039	6.5	.256	6	3	462.1-0990-065A0-XM	*	*	*	*	*	*	*	*	*	*	3.0	.118	38	1.496	37.8	1.487	8	.315	0.2	.009				
1.00	.039	6.5	.256	6	3	462.1-1000-065A0-XM	*	*	*	*	*	*	*	*	*	*	3.0	.118	38	1.496	37.8	1.487	8	.315	0.2	.009				
1.01	.040	6.5	.256	6	3	462.1-1010-065A0-XM	*	*	*	*	*	*	*	*	*	*	3.0	.118	38	1.496	37.8	1.487	8	.315	0.2	.009				
1.02	.040	6.5	.256	6	3	462.1-1020-065A0-XM	*	*	*	*	*	*	*	*	*	*	3.0	.118	38	1.496	37.8	1.487	8	.315	0.2	.009				
1.03	.041	6.5	.256	6	3	462.1-1030-065A0-XM	*	*	*	*	*	*	*	*	*	*	3.0	.118	38	1.496	37.8	1.487	8	.315	0.2	.009				
1.04	.041	6.5	.256	6	3	462.1-1040-065A0-XM	*	*	*	*	*	*	*	*	*	*	3.0	.118	38	1.496	37.8	1.487	8	.315	0.2	.010				
1.05	.041	6.5	.256	6	3	462.1-1050-065A0-XM	*	*	*	*	*	*	*	*	*	*	3.0	.118	38	1.496	37.8	1.487	8	.315	0.2	.010				
1.06	.042	7.3	.287	6	3	462.1-1060-073A0-XM	*	*	*	*	*	*	*	*	*	*	3.0	.118	38	1.496	37.8	1.486	9	.354	0.2	.010				
1.07	.042	7.3	.287	6	3	462.1-1070-073A0-XM	*	*	*	*	*	*	*	*	*	*	3.0	.118	38	1.496	37.8	1.486	9	.354	0.2	.010				
1.08	.043	7.3	.287	6	3	462.1-1080-073A0-XM	*	*	*	*	*	*	*	*	*	*	3.0	.118	38	1.496	37.8	1.486	9	.354	0.3	.010				
1.09	.043	7.3	.287	6	3	462.1-1090-073A0-XM	*	*	*	*	*	*	*	*	*	*	3.0	.118	38	1.496	37.8	1.486	9	.354	0.3	.010				
1.10	.043	7.3	.287	6	3	462.1-1100-073A0-XM	*	*	*	*	*	*	*	*	*	*	3.0	.118	38	1.496	37.7	1.486	9	.354	0.3	.010				
1.11	.044	7.3	.287	6	3	462.1-1110-073A0-XM	*	*	*	*	*	*	*	*	*	*	3.0	.118	38	1.496	37.7	1.486	9	.354	0.3	.010				
1.12	.044	7.3	.287	6	3	462.1-1120-073A0-XM	*	*	*	*	*	*	*	*	*	*	3.0	.118	38	1.496	37.7	1.486	9	.354	0.3	.010				
1.13	.044	7.3	.287	6	3	462.1-1130-073A0-XM	*	*	*	*	*	*	*	*	*	*	3.0	.118	38	1.496	37.7	1.486	9	.354	0.3	.010				
1.14	.045	7.3	.287	6	3	462.1-1140-073A0-XM	*	*	*	*	*	*	*	*	*	*	3.0	.118	38	1.496	37.7	1.485	9	.354	0.3	.010				
1.15	.045	7.3	.287	6	3	462.1-1150-073A0-XM	*	*	*	*	*	*	*	*	*	*	3.0	.118	38	1.496	37.7	1.485	9	.354	0.3	.011				
1.16	.046	8.2	.323	7	3	462.1-1160-082A0-XM	*	*	*	*	*	*	*	*	*	*	3.0	.118	38	1.496	37.7	1.485	10	.394	0.3	.011				
1.17	.046	8.2	.323	7	3	462.1-1170-082A0-XM	*	*	*	*	*	*	*	*	*	*	3.0	.118	38	1.496	37.7	1.485	10	.394	0.3	.011				
1.18	.046	8.2	.323	6	3	462.1-1180-082A0-XM	*	*	*	*	*	*	*	*	*	*	3.0	.118	38	1.496	37.7	1.485	10	.394	0.3	.011				
1.19	.047	8.2	.323	6	3	462.1-1190-082A0-XM	*	*	*	*	*	*	*	*	*	*	3.0	.118	38	1.496	37.7	1.485	10	.394	0.3	.011				
1.20	.047	8.2	.323	6	3	462.1-1200-082A0-XM	*	*	*	*	*	*	*	*	*	*	3.0	.118	38	1.496	37.7	1.485	10	.394	0.3	.011				



CoroDrill® 462-XM solid carbide micro drill

Coated (6xD)

External coolant supply

TCHA JS7
SIG 130°

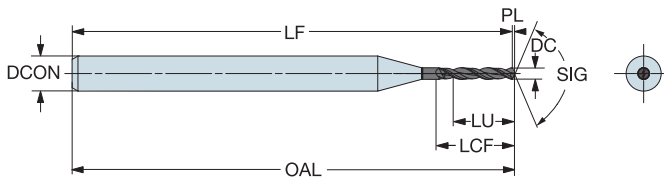

DC	DC*	LU	LU*	ULDR	CZG _{MS}	Ordering code	Material						Dimensions, mm, inch										
							P	M	K	N	S	H	O	DCON _{MS}	DCON _{MS} *	OAL	OAL*	LF	LF*	LCF	LCF*	PL	PL*
							XZBM	XZBM	XZBM	XZBM	XZBM	XZBM	XZBM										
1.21	.048	8.2	.323	6	3	462.1-1210-082A0-XM	*	*	*	*	*	*	*	3.0	.118	38	1.496	37.7	1.485	10	.394	0.3	.011
1.22	.048	8.2	.323	6	3	462.1-1220-082A0-XM	*	*	*	*	*	*	*	3.0	.118	38	1.496	37.7	1.485	10	.394	0.3	.011
1.23	.048	8.2	.323	6	3	462.1-1230-082A0-XM	*	*	*	*	*	*	*	3.0	.118	38	1.496	37.7	1.485	10	.394	0.3	.011
1.24	.049	8.2	.323	6	3	462.1-1240-082A0-XM	*	*	*	*	*	*	*	3.0	.118	38	1.496	37.7	1.485	10	.394	0.3	.011
1.25	.049	8.2	.323	6	3	462.1-1250-082A0-XM	*	*	*	*	*	*	*	3.0	.118	38	1.496	37.7	1.485	10	.394	0.3	.011
1.26	.050	8.2	.323	6	3	462.1-1260-082A0-XM	*	*	*	*	*	*	*	3.0	.118	38	1.496	37.7	1.485	10	.394	0.3	.012
1.27	.050	8.2	.323	6	3	462.1-1270-082A0-XM	*	*	*	*	*	*	*	3.0	.118	38	1.496	37.7	1.484	10	.394	0.3	.012
1.28	.050	8.2	.323	6	3	462.1-1280-082A0-XM	*	*	*	*	*	*	*	3.0	.118	38	1.496	37.7	1.484	10	.394	0.3	.012
1.29	.051	8.2	.323	6	3	462.1-1290-082A0-XM	*	*	*	*	*	*	*	3.0	.118	38	1.496	37.7	1.484	10	.394	0.3	.012
1.30	.051	8.2	.323	6	3	462.1-1300-082A0-XM	*	*	*	*	*	*	*	3.0	.118	38	1.496	37.7	1.484	10	.394	0.3	.012
1.31	.052	9.2	.362	7	3	462.1-1310-092A0-XM	*	*	*	*	*	*	*	3.0	.118	38	1.496	37.7	1.484	11	.441	0.3	.012
1.32	.052	9.2	.362	6	3	462.1-1320-092A0-XM	*	*	*	*	*	*	*	3.0	.118	38	1.496	37.7	1.484	11	.441	0.3	.012
1.33	.052	9.2	.362	6	3	462.1-1330-092A0-XM	*	*	*	*	*	*	*	3.0	.118	38	1.496	37.7	1.484	11	.441	0.3	.012
1.34	.053	9.2	.362	6	3	462.1-1340-092A0-XM	*	*	*	*	*	*	*	3.0	.118	38	1.496	37.7	1.484	11	.441	0.3	.012
1.35	.053	9.2	.362	6	3	462.1-1350-092A0-XM	*	*	*	*	*	*	*	3.0	.118	38	1.496	37.7	1.484	11	.441	0.3	.012
1.36	.054	9.2	.362	6	3	462.1-1360-092A0-XM	*	*	*	*	*	*	*	3.0	.118	38	1.496	37.7	1.483	11	.441	0.3	.012
1.37	.054	9.2	.362	6	3	462.1-1370-092A0-XM	*	*	*	*	*	*	*	3.0	.118	38	1.496	37.7	1.483	11	.441	0.3	.013
1.38	.054	9.2	.362	6	3	462.1-1380-092A0-XM	*	*	*	*	*	*	*	3.0	.118	38	1.496	37.7	1.483	11	.441	0.3	.013
1.39	.055	9.2	.362	6	3	462.1-1390-092A0-XM	*	*	*	*	*	*	*	3.0	.118	38	1.496	37.7	1.483	11	.441	0.3	.013
1.40	.055	9.2	.362	6	3	462.1-1400-092A0-XM	*	*	*	*	*	*	*	3.0	.118	38	1.496	37.7	1.483	11	.441	0.3	.013
1.41	.056	9.2	.362	6	3	462.1-1410-092A0-XM	*	*	*	*	*	*	*	3.0	.118	38	1.496	37.7	1.483	11	.441	0.3	.013
1.42	.056	9.2	.362	6	3	462.1-1420-092A0-XM	*	*	*	*	*	*	*	3.0	.118	38	1.496	37.7	1.483	11	.441	0.3	.013
1.43	.056	9.2	.362	6	3	462.1-1430-092A0-XM	*	*	*	*	*	*	*	3.0	.118	38	1.496	37.7	1.483	11	.441	0.3	.013
1.44	.057	9.2	.362	6	3	462.1-1440-092A0-XM	*	*	*	*	*	*	*	3.0	.118	38	1.496	37.7	1.483	11	.441	0.3	.013
1.45	.057	9.2	.362	6	3	462.1-1450-092A0-XM	*	*	*	*	*	*	*	3.0	.118	38	1.496	37.7	1.483	11	.441	0.3	.013
1.46	.057	9.2	.362	6	3	462.1-1460-092A0-XM	*	*	*	*	*	*	*	3.0	.118	38	1.496	37.7	1.483	11	.441	0.3	.013
1.47	.058	9.2	.362	6	3	462.1-1470-092A0-XM	*	*	*	*	*	*	*	3.0	.118	38	1.496	37.7	1.483	11	.441	0.3	.013
1.48	.058	9.2	.362	6	3	462.1-1480-092A0-XM	*	*	*	*	*	*	*	3.0	.118	38	1.496	37.7	1.482	11	.441	0.3	.014
1.49	.059	9.2	.362	6	3	462.1-1490-092A0-XM	*	*	*	*	*	*	*	3.0	.118	38	1.496	37.7	1.482	11	.441	0.3	.014
1.50	.059	9.2	.362	6	3	462.1-1500-092A0-XM	*	*	*	*	*	*	*	3.0	.118	38	1.496	37.7	1.482	11	.441	0.3	.014
1.51	.059	11.2	.441	7	3	462.1-1510-112A0-XM	*	*	*	*	*	*	*	3.0	.118	38	1.496	37.7	1.482	13	.528	0.4	.014
1.52	.060	11.2	.441	7	3	462.1-1520-112A0-XM	*	*	*	*	*	*	*	3.0	.118	38	1.496	37.7	1.482	13	.528	0.4	.014
1.53	.060	11.2	.441	7	3	462.1-1530-112A0-XM	*	*	*	*	*	*	*	3.0	.118	38	1.496	37.6	1.482	13	.528	0.4	.014
1.54	.061	11.2	.441	7	3	462.1-1540-112A0-XM	*	*	*	*	*	*	*	3.0	.118	38	1.496	37.6	1.482	13	.528	0.4	.014
1.55	.061	11.2	.441	7	3	462.1-1550-112A0-XM	*	*	*	*	*	*	*	3.0	.118	38	1.496	37.6	1.482	13	.528	0.4	.014
1.56	.061	11.2	.441	7	3	462.1-1560-112A0-XM	*	*	*	*	*	*	*	3.0	.118	38	1.496	37.6	1.482	13	.528	0.4	.014
1.57	.062	11.2	.441	7	3	462.1-1570-112A0-XM	*	*	*	*	*	*	*	3.0	.118	38	1.496	37.6	1.482	13	.528	0.4	.014
1.58	.062	11.2	.441	7	3	462.1-1580-112A0-XM	*	*	*	*	*	*	*	3.0	.118	38	1.496	37.6	1.482	13	.528	0.4	.015
1.59	.063	11.2	.441	7	3	462.1-1590-112A0-XM	*	*	*	*	*	*	*	3.0	.118	38	1.496	37.6	1.482	13	.528	0.4	.015
1.60	.063	11.2	.441	7	3	462.1-1600-112A0-XM	*	*	*	*	*	*	*	3.0	.118	38	1.496	37.6	1.482	13	.528	0.4	.015
1.61	.063	11.2	.441	6	3	462.1-1610-112A0-XM	*	*	*	*	*	*	*	3.0	.118	38	1.496	37.6	1.481	13	.528	0.4	.015
1.62	.064	11.2	.441	6	3	462.1-1620-112A0-XM	*	*	*	*	*	*	*	3.0	.118	38	1.496	37.6	1.481	13	.528	0.4	.015
1.63	.064	11.2	.441	6	3	462.1-1630-112A0-XM	*	*	*	*	*	*	*	3.0	.118	38	1.496	37.6	1.481	13	.528	0.4	.015
1.64	.065	11.2	.441	6	3	462.1-1640-112A0-XM	*	*	*	*	*	*	*	3.0	.118	38	1.496	37.6	1.481	13	.528	0.4	.015
1.65	.065	11.2	.441	6	3	462.1-1650-112A0-XM	*	*	*	*	*	*	*	3.0	.118	38	1.496	37.6	1.481	13	.528	0.4	.015
1.66	.065	11.2	.441	6	3	462.1-1660-112A0-XM	*	*	*	*	*	*	*	3.0	.118	38	1.496	37.6	1.481	13	.528	0.4	.015
1.67	.066	11.2	.441	6	3	462.1-1670-112A0-XM	*	*	*	*	*	*	*	3.0	.118	38	1.496	37.6	1.481	13	.528	0.4	.015
1.68	.066	11.2	.441	6	3	462.1-1680-112A0-XM	*	*	*	*	*	*	*	3.0	.118	38	1.496	37.6	1.481	13	.528	0.4	.015
1.69	.067	11.2	.441	6	3	462.1-1690-112A0-XM	*	*	*	*	*	*	*	3.0	.118	38	1.496	37.6	1.481	13	.528	0.4	.016
1.70	.067	11.2	.441	6	3	462.1-1700-112A0-XM	*	*	*	*	*	*	*	3.0	.118	38	1.496	37.6	1.480	13	.528	0.4	.016
1.71	.067	11.2	.441	6	3	462.1-1710-112A0-XM	*	*	*	*	*	*	*	3.0	.118	38	1.496	37.6	1.480	13	.528	0.4	.016



CoroDrill® 462-XM solid carbide micro drill

Coated (6xD)

External coolant supply

TCHA JS7
SIG 130°

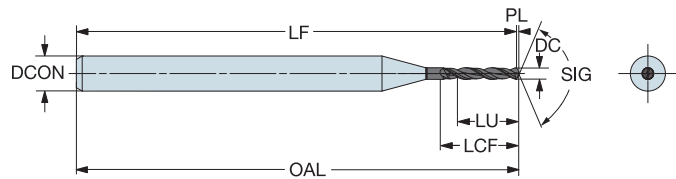
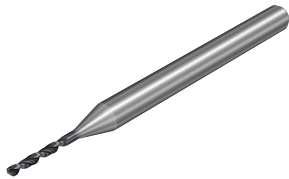

DC	DC*	LU	LU*	ULDR	CZC _{MS}	Ordering code	P M K N S H O						Dimensions, mm, inch											
							XZBM	XZBM	XZBM	XZBM	XZBM	XZBM	XZBM	XZBM	DCON _{MS}	DCON _{MS} "	OAL	OAL"	LF	LF*	LCF	LCF*	PL	PL"
1.72	.068	11.2	.441	6	3	462.1-1720-112A0-XM	*	*	*	*	*	*	*	3.0	.118	38	1.496	37.6	1.480	13	.528	0.4	.016	
1.73	.068	11.2	.441	6	3	462.1-1730-112A0-XM	*	*	*	*	*	*	*	3.0	.118	38	1.496	37.6	1.480	13	.528	0.4	.016	
1.74	.069	11.2	.441	6	3	462.1-1740-112A0-XM	*	*	*	*	*	*	*	3.0	.118	38	1.496	37.6	1.480	13	.528	0.4	.016	
1.75	.069	11.2	.441	6	3	462.1-1750-112A0-XM	*	*	*	*	*	*	*	3.0	.118	38	1.496	37.6	1.480	13	.528	0.4	.016	
1.76	.069	11.2	.441	6	3	462.1-1760-112A0-XM	*	*	*	*	*	*	*	3.0	.118	38	1.496	37.6	1.480	13	.528	0.4	.016	
1.77	.070	11.2	.441	6	3	462.1-1770-112A0-XM	*	*	*	*	*	*	*	3.0	.118	38	1.496	37.6	1.480	13	.528	0.4	.016	
1.78	.070	11.2	.441	6	3	462.1-1780-112A0-XM	*	*	*	*	*	*	*	3.0	.118	38	1.496	37.6	1.480	13	.528	0.4	.016	
1.79	.070	11.2	.441	6	3	462.1-1790-112A0-XM	*	*	*	*	*	*	*	3.0	.118	38	1.496	37.6	1.480	13	.528	0.4	.016	
1.80	.071	11.2	.441	6	3	462.1-1800-112A0-XM	*	*	*	*	*	*	*	3.0	.118	38	1.496	37.6	1.480	13	.528	0.4	.017	
1.81	.071	11.2	.441	6	3	462.1-1810-112A0-XM	*	*	*	*	*	*	*	3.0	.118	38	1.496	37.6	1.480	13	.528	0.4	.017	
1.82	.072	11.2	.441	6	3	462.1-1820-112A0-XM	*	*	*	*	*	*	*	3.0	.118	38	1.496	37.6	1.480	13	.528	0.4	.017	
1.83	.072	11.2	.441	6	3	462.1-1830-112A0-XM	*	*	*	*	*	*	*	3.0	.118	38	1.496	37.6	1.479	13	.528	0.4	.017	
1.84	.072	11.2	.441	6	3	462.1-1840-112A0-XM	*	*	*	*	*	*	*	3.0	.118	38	1.496	37.6	1.479	13	.528	0.4	.017	
1.85	.073	11.2	.441	6	3	462.1-1850-112A0-XM	*	*	*	*	*	*	*	3.0	.118	38	1.496	37.6	1.479	13	.528	0.4	.017	
1.86	.073	11.2	.441	6	3	462.1-1860-112A0-XM	*	*	*	*	*	*	*	3.0	.118	38	1.496	37.6	1.479	13	.528	0.4	.017	
1.87	.074	11.2	.441	5	3	462.1-1870-112A0-XM	*	*	*	*	*	*	*	3.0	.118	38	1.496	37.6	1.479	13	.528	0.4	.017	
1.88	.074	11.2	.441	5	3	462.1-1880-112A0-XM	*	*	*	*	*	*	*	3.0	.118	38	1.496	37.6	1.479	13	.528	0.4	.017	
1.89	.074	11.2	.441	5	3	462.1-1890-112A0-XM	*	*	*	*	*	*	*	3.0	.118	38	1.496	37.6	1.479	13	.528	0.4	.017	
1.90	.075	11.2	.441	5	3	462.1-1900-112A0-XM	*	*	*	*	*	*	*	3.0	.118	38	1.496	37.6	1.479	13	.528	0.4	.017	
1.91	.075	11.2	.441	5	3	462.1-1910-112A0-XM	*	*	*	*	*	*	*	3.0	.118	38	1.496	37.6	1.478	13	.528	0.4	.018	
1.92	.076	11.2	.441	5	3	462.1-1920-112A0-XM	*	*	*	*	*	*	*	3.0	.118	38	1.496	37.6	1.478	13	.528	0.4	.018	
1.93	.076	11.2	.441	5	3	462.1-1930-112A0-XM	*	*	*	*	*	*	*	3.0	.118	38	1.496	37.6	1.478	13	.528	0.4	.018	
1.94	.076	11.2	.441	5	3	462.1-1940-112A0-XM	*	*	*	*	*	*	*	3.0	.118	38	1.496	37.6	1.478	13	.528	0.5	.018	
1.95	.077	11.2	.441	5	3	462.1-1950-112A0-XM	*	*	*	*	*	*	*	3.0	.118	38	1.496	37.6	1.478	13	.528	0.5	.018	
1.96	.077	11.2	.441	5	3	462.1-1960-112A0-XM	*	*	*	*	*	*	*	3.0	.118	38	1.496	37.5	1.478	13	.528	0.5	.018	
1.97	.078	11.2	.441	5	3	462.1-1970-112A0-XM	*	*	*	*	*	*	*	3.0	.118	38	1.496	37.5	1.478	13	.528	0.5	.018	
1.98	.078	11.2	.441	5	3	462.1-1980-112A0-XM	*	*	*	*	*	*	*	3.0	.118	38	1.496	37.5	1.478	13	.528	0.5	.018	
1.99	.078	11.2	.441	5	3	462.1-1990-112A0-XM	*	*	*	*	*	*	*	3.0	.118	38	1.496	37.5	1.478	13	.528	0.5	.018	
2.00	.079	11.2	.441	5	3	462.1-2000-112A0-XM	*	*	*	*	*	*	*	3.0	.118	38	1.496	37.5	1.478	13	.528	0.5	.018	
2.01	.079	12.5	.492	6	3	462.1-2010-125A0-XM	*	*	*	*	*	*	*	3.0	.118	38	1.496	37.5	1.478	14	.551	0.5	.018	
2.02	.080	12.5	.492	6	3	462.1-2020-125A0-XM	*	*	*	*	*	*	*	3.0	.118	38	1.496	37.5	1.478	14	.551	0.5	.019	
2.03	.080	12.5	.492	6	3	462.1-2030-125A0-XM	*	*	*	*	*	*	*	3.0	.118	38	1.496	37.5	1.478	14	.551	0.5	.019	
2.04	.080	12.5	.492	6	3	462.1-2040-125A0-XM	*	*	*	*	*	*	*	3.0	.118	38	1.496	37.5	1.477	14	.551	0.5	.019	
2.05	.081	12.5	.492	6	3	462.1-2050-125A0-XM	*	*	*	*	*	*	*	3.0	.118	38	1.496	37.5	1.477	14	.551	0.5	.019	
2.06	.081	12.5	.492	6	3	462.1-2060-125A0-XM	*	*	*	*	*	*	*	3.0	.118	38	1.496	37.5	1.477	14	.551	0.5	.019	
2.07	.081	12.5	.492	6	3	462.1-2070-125A0-XM	*	*	*	*	*	*	*	3.0	.118	38	1.496	37.5	1.477	14	.551	0.5	.019	
2.08	.082	12.5	.492	6	3	462.1-2080-125A0-XM	*	*	*	*	*	*	*	3.0	.118	38	1.496	37.5	1.477	14	.551	0.5	.019	
2.09	.082	12.5	.492	5	3	462.1-2090-125A0-XM	*	*	*	*	*	*	*	3.0	.118	38	1.496	37.5	1.477	14	.551	0.5	.019	
2.10	.083	12.5	.492	5	3	462.1-2100-125A0-XM	*	*	*	*	*	*	*	3.0	.118	38	1.496	37.5	1.477	14	.551	0.5	.019	
2.11	.083	12.5	.492	5	3	462.1-2110-125A0-XM	*	*	*	*	*	*	*	3.0	.118	38	1.496	37.5	1.477	14	.551	0.5	.019	
2.12	.083	12.5	.492	5	3	462.1-2120-125A0-XM	*	*	*	*	*	*	*	3.0	.118	38	1.496	37.5	1.477	14	.551	0.5	.019	
2.13	.084	12.5	.492	5	3	462.1-2130-125A0-XM	*	*	*	*	*	*	*	3.0	.118	38	1.496	37.5	1.476	14	.551	0.5	.020	
2.14	.084	12.5	.492	5	3	462.1-2140-125A0-XM	*	*	*	*	*	*	*	3.0	.118	38	1.496	37.5	1.476	14	.551	0.5	.020	
2.15	.085	12.5	.492	5	3	462.1-2150-125A0-XM	*	*	*	*	*	*	*	3.0	.118	38	1.496	37.5	1.476	14	.551	0.5	.020	
2.16	.085	12.5	.492	5	3	462.1-2160-125A0-XM	*	*	*	*	*	*	*	3.0	.118	38	1.496	37.5	1.476	14	.551	0.5	.020	
2.17	.085	12.5	.492	5	3	462.1-2170-125A0-XM	*	*	*	*	*	*	*	3.0	.118	38	1.496	37.5	1.476	14	.551	0.5	.020	
2.18	.086	12.5	.492	5	3	462.1-2180-125A0-XM	*	*	*	*	*	*	*	3.0	.118	38	1.496	37.5	1.476	14	.551	0.5	.020	
2.19	.086	12.5	.492	5	3	462.1-2190-125A0-XM	*	*	*	*	*	*	*	3.0	.118	38	1.496	37.5	1.476	14	.551	0.5	.020	
2.20	.087	12.5	.492	5	3	462.1-2200-125A0-XM	*	*	*	*	*	*	*	3.0	.118	38	1.496	37.5	1.476	14	.551	0.5	.020	
2.21	.087	12.5	.492	5	3	462.1-2210-125A0-XM	*	*	*	*	*	*	*	3.0	.118	38	1.496	37.5	1.476	14	.551	0.5	.020	
2.22	.087	12.5	.492	5	3	462.1-2220-125A0-XM	*	*	*	*	*	*	*	3.0	.118	38	1.496	37.5	1.476	14	.551	0.5	.020	



CoroDrill® 462-XM solid carbide micro drill

Coated (6xD)

External coolant supply

TCHA JS7
SIG 130°

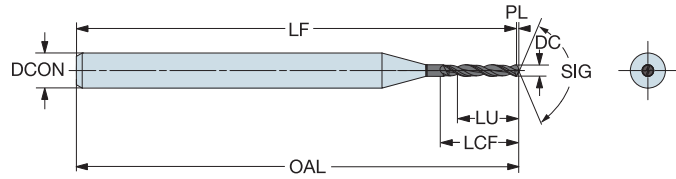

DC	DC*	LU	LU*	ULDR	CZC _{MS}	Ordering code	P M K N S H O										Dimensions, mm, inch													
							P		M		K		N		S		H		O		DCON _{MS}	DCON _{MS} "	OAL	OAL"	LF	LF"	LCF	LCF"	PL	PL"
							XZBM	XZBM	XZBM	XZBM	XZBM	XZBM	XZBM	XZBM	XZBM	XZBM	XZBM	XZBM	XZBM	XZBM										
2.74	.108	14.0	.551	5	3	462.1-2740-140A0-XM	*	*	*	*	*	*	*	*	*	*	3.0	.118	38	1.496	37.4	1.471	17	.669	0.6	.025				
2.75	.108	14.0	.551	5	3	462.1-2750-140A0-XM	*	*	*	*	*	*	*	*	*	*	3.0	.118	38	1.496	37.4	1.471	17	.669	0.6	.025				
2.76	.109	14.0	.551	5	3	462.1-2760-140A0-XM	*	*	*	*	*	*	*	*	*	*	3.0	.118	38	1.496	37.4	1.471	17	.669	0.6	.025				
2.77	.109	14.0	.551	5	3	462.1-2770-140A0-XM	*	*	*	*	*	*	*	*	*	*	3.0	.118	38	1.496	37.4	1.470	17	.669	0.6	.025				
2.78	.109	14.0	.551	5	3	462.1-2780-140A0-XM	*	*	*	*	*	*	*	*	*	*	3.0	.118	38	1.496	37.4	1.470	17	.669	0.6	.026				
2.79	.110	14.0	.551	5	3	462.1-2790-140A0-XM	*	*	*	*	*	*	*	*	*	*	3.0	.118	38	1.496	37.4	1.470	17	.669	0.7	.026				
2.80	.110	14.0	.551	5	3	462.1-2800-140A0-XM	*	*	*	*	*	*	*	*	*	*	3.0	.118	38	1.496	37.4	1.470	17	.669	0.7	.026				
2.81	.111	14.0	.551	4	3	462.1-2810-140A0-XM	*	*	*	*	*	*	*	*	*	*	3.0	.118	38	1.496	37.3	1.470	17	.669	0.7	.026				
2.82	.111	14.0	.551	4	3	462.1-2820-140A0-XM	*	*	*	*	*	*	*	*	*	*	3.0	.118	38	1.496	37.3	1.470	17	.669	0.7	.026				
2.83	.111	14.0	.551	4	3	462.1-2830-140A0-XM	*	*	*	*	*	*	*	*	*	*	3.0	.118	38	1.496	37.3	1.470	17	.669	0.7	.026				
2.84	.112	14.0	.551	4	3	462.1-2840-140A0-XM	*	*	*	*	*	*	*	*	*	*	3.0	.118	38	1.496	37.3	1.470	17	.669	0.7	.026				
2.85	.112	14.0	.551	4	3	462.1-2850-140A0-XM	*	*	*	*	*	*	*	*	*	*	3.0	.118	38	1.496	37.3	1.470	17	.669	0.7	.026				
2.86	.113	14.0	.551	4	3	462.1-2860-140A0-XM	*	*	*	*	*	*	*	*	*	*	3.0	.118	38	1.496	37.3	1.470	17	.669	0.7	.026				
2.87	.113	14.0	.551	4	3	462.1-2870-140A0-XM	*	*	*	*	*	*	*	*	*	*	3.0	.118	38	1.496	37.3	1.470	17	.669	0.7	.026				
2.88	.113	14.0	.551	4	3	462.1-2880-140A0-XM	*	*	*	*	*	*	*	*	*	*	3.0	.118	38	1.496	37.3	1.470	17	.669	0.7	.026				
2.89	.114	14.0	.551	4	3	462.1-2890-140A0-XM	*	*	*	*	*	*	*	*	*	*	3.0	.118	38	1.496	37.3	1.470	17	.669	0.7	.027				
2.90	.114	14.0	.551	4	3	462.1-2900-140A0-XM	*	*	*	*	*	*	*	*	*	*	3.0	.118	38	1.496	37.3	1.469	17	.669	0.7	.027				
2.91	.115	14.0	.551	4	3	462.1-2910-140A0-XM	*	*	*	*	*	*	*	*	*	*	3.0	.118	38	1.496	37.3	1.469	17	.669	0.7	.027				
2.92	.115	14.0	.551	4	3	462.1-2920-140A0-XM	*	*	*	*	*	*	*	*	*	*	3.0	.118	38	1.496	37.3	1.469	17	.669	0.7	.027				
2.93	.115	14.0	.551	4	3	462.1-2930-140A0-XM	*	*	*	*	*	*	*	*	*	*	3.0	.118	38	1.496	37.3	1.469	17	.669	0.7	.027				
2.94	.116	14.0	.551	4	3	462.1-2940-140A0-XM	*	*	*	*	*	*	*	*	*	*	3.0	.118	38	1.496	37.3	1.469	17	.669	0.7	.027				
2.95	.116	14.0	.551	4	3	462.1-2950-140A0-XM	*	*	*	*	*	*	*	*	*	*	3.0	.118	38	1.496	37.3	1.469	17	.669	0.7	.027				
2.96	.117	14.0	.551	4	3	462.1-2960-140A0-XM	*	*	*	*	*	*	*	*	*	*	3.0	.118	38	1.496	37.3	1.469	17	.669	0.7	.027				
2.97	.117	14.0	.551	4	3	462.1-2970-140A0-XM	*	*	*	*	*	*	*	*	*	*	3.0	.118	38	1.496	37.3	1.469	17	.669	0.7	.027				
2.98	.117	14.0	.551	4	3	462.1-2980-140A0-XM	*	*	*	*	*	*	*	*	*	*	3.0	.118	38	1.496	37.3	1.469	17	.669	0.7	.027				
2.99	.118	14.0	.551	4	3	462.1-2990-140A0-XM	*	*	*	*	*	*	*	*	*	*	3.0	.118	38	1.496	37.3	1.469	17	.669	0.7	.027				
3.00	.118	14.0	.551	4	3	462.1-3000-140A0-XM	*	*	*	*	*	*	*	*	*	*	3.0	.118	38	1.496	37.3	1.469	17	.669	0.7	.028				



CoroDrill® 862-GM solid carbide micro drill

External coolant supply

9xD

TCHA H7
SIG 140°

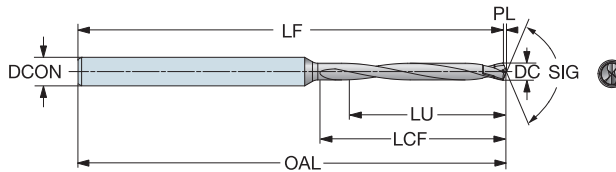
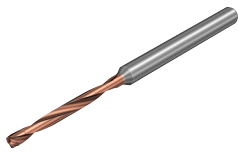

DC	DC*	LU	LU*	ULDR	CZG _{MS}	Ordering code	Material						Dimensions, mm, inch												
							P	M	K	N	S	H	O	DCON _{MS}	DCON _{MS} *	OAL	OAL*	LF	LF*	LCF	LCF*	PL	PL*		
0.30	.012	2.7	.106	9	3	862.1-0300-027A0-GM	☆	☆	☆	☆	☆	☆	☆	☆	☆	3.0	.118	38	1.496	38.0	1.494	3	.130	0.1	.002
0.35	.014	3.2	.124	9	3	862.1-0350-031A0-GM	☆	☆	☆	☆	☆	☆	☆	☆	☆	3.0	.118	38	1.496	37.9	1.494	3	.154	0.1	.003
0.40	.016	3.6	.142	9	3	862.1-0400-036A0-GM	☆	☆	☆	☆	☆	☆	☆	☆	☆	3.0	.118	38	1.496	37.9	1.493	4	.173	0.1	.003
0.45	.018	4.1	.159	9	3	862.1-0450-040A0-GM	☆	☆	☆	☆	☆	☆	☆	☆	☆	3.0	.118	38	1.496	37.9	1.493	5	.197	0.1	.003
0.50	.020	4.5	.177	9	3	862.1-0500-045A0-GM	☆	☆	☆	☆	☆	☆	☆	☆	☆	3.0	.118	38	1.496	37.9	1.493	5	.217	0.1	.004
0.55	.022	5.0	.195	9	3	862.1-0550-049A0-GM	☆	☆	☆	☆	☆	☆	☆	☆	☆	3.0	.118	38	1.496	37.9	1.492	6	.240	0.1	.004
0.60	.024	5.4	.213	9	3	862.1-0600-054A0-GM	☆	☆	☆	☆	☆	☆	☆	☆	☆	3.0	.118	38	1.496	37.9	1.492	6	.260	0.1	.004
0.65	.026	5.9	.230	9	3	862.1-0650-058A0-GM	☆	☆	☆	☆	☆	☆	☆	☆	☆	3.0	.118	38	1.496	37.9	1.491	7	.283	0.1	.005
0.70	.028	6.3	.248	9	3	862.1-0700-063A0-GM	☆	☆	☆	☆	☆	☆	☆	☆	☆	3.0	.118	38	1.496	37.9	1.491	7	.303	0.1	.005
0.75	.030	6.8	.266	9	3	862.1-0750-067A0-GM	☆	☆	☆	☆	☆	☆	☆	☆	☆	3.0	.118	40	1.575	39.9	1.569	8	.327	0.1	.005
0.80	.031	7.2	.283	9	3	862.1-0800-072A0-GM	☆	☆	☆	☆	☆	☆	☆	☆	☆	3.0	.118	40	1.575	39.9	1.569	8	.346	0.1	.006
0.85	.033	7.7	.301	9	3	862.1-0850-076A0-GM	☆	☆	☆	☆	☆	☆	☆	☆	☆	3.0	.118	40	1.575	39.9	1.569	9	.370	0.2	.006
0.90	.035	8.1	.319	9	3	862.1-0900-081A0-GM	☆	☆	☆	☆	☆	☆	☆	☆	☆	3.0	.118	40	1.575	39.8	1.569	9	.390	0.2	.006
0.95	.037	8.6	.337	9	3	862.1-0950-085A0-GM	☆	☆	☆	☆	☆	☆	☆	☆	☆	3.0	.118	45	1.772	44.8	1.765	10	.413	0.2	.007
1.00	.039	9.0	.354	9	3	862.1-1000-090A0-GM	☆	☆	☆	☆	☆	☆	☆	☆	☆	3.0	.118	45	1.772	44.8	1.765	11	.433	0.2	.007
1.05	.041	9.5	.372	9	3	862.1-1050-094A0-GM	☆	☆	☆	☆	☆	☆	☆	☆	☆	3.0	.118	45	1.772	44.8	1.764	11	.457	0.2	.008
1.10	.043	9.9	.390	9	3	862.1-1100-099A0-GM	☆	☆	☆	☆	☆	☆	☆	☆	☆	3.0	.118	45	1.772	44.8	1.764	12	.476	0.2	.008
1.15	.045	10.4	.407	9	3	862.1-1150-103A0-GM	☆	☆	☆	☆	☆	☆	☆	☆	☆	3.0	.118	45	1.772	44.8	1.763	12	.500	0.2	.008
1.20	.047	10.8	.425	9	3	862.1-1200-108A0-GM	☆	☆	☆	☆	☆	☆	☆	☆	☆	3.0	.118	45	1.772	44.8	1.763	13	.520	0.2	.009
1.25	.049	11.3	.443	9	3	862.1-1250-112A0-GM	☆	☆	☆	☆	☆	☆	☆	☆	☆	3.0	.118	45	1.772	44.8	1.763	13	.543	0.2	.009
1.30	.051	11.7	.461	9	3	862.1-1300-117A0-GM	☆	☆	☆	☆	☆	☆	☆	☆	☆	3.0	.118	45	1.772	44.8	1.762	14	.563	0.2	.009
1.35	.053	12.2	.478	9	3	862.1-1350-121A0-GM	☆	☆	☆	☆	☆	☆	☆	☆	☆	3.0	.118	45	1.772	44.8	1.762	14	.587	0.2	.010
1.40	.055	12.6	.496	9	3	862.1-1400-126A0-GM	☆	☆	☆	☆	☆	☆	☆	☆	☆	3.0	.118	45	1.772	44.8	1.762	15	.606	0.3	.010
1.45	.057	13.1	.514	9	3	862.1-1450-130A0-GM	☆	☆	☆	☆	☆	☆	☆	☆	☆	3.0	.118	45	1.772	44.7	1.761	16	.630	0.3	.010
1.50	.059	13.5	.531	9	3	862.1-1500-135A0-GM	☆	☆	☆	☆	☆	☆	☆	☆	☆	3.0	.118	45	1.772	44.7	1.761	16	.650	0.3	.011
1.55	.061	14.0	.549	9	3	862.1-1550-139A0-GM	☆	☆	☆	☆	☆	☆	☆	☆	☆	3.0	.118	50	1.969	49.7	1.957	17	.673	0.3	.011
1.60	.063	14.4	.567	9	3	862.1-1600-144A0-GM	☆	☆	☆	☆	☆	☆	☆	☆	☆	3.0	.118	50	1.969	49.7	1.957	17	.693	0.3	.011
1.65	.065	14.9	.585	9	3	862.1-1650-148A0-GM	☆	☆	☆	☆	☆	☆	☆	☆	☆	3.0	.118	50	1.969	49.7	1.957	18	.717	0.3	.012
1.70	.067	15.3	.602	9	3	862.1-1700-153A0-GM	☆	☆	☆	☆	☆	☆	☆	☆	☆	3.0	.118	50	1.969	49.7	1.956	18	.736	0.3	.012
1.75	.069	15.8	.620	9	3	862.1-1750-157A0-GM	☆	☆	☆	☆	☆	☆	☆	☆	☆	3.0	.118	50	1.969	49.7	1.956	19	.760	0.3	.013
1.80	.071	16.2	.638	9	3	862.1-1800-162A0-GM	☆	☆	☆	☆	☆	☆	☆	☆	☆	3.0	.118	50	1.969	49.7	1.956	19	.780	0.3	.013
1.85	.073	16.7	.656	9	3	862.1-1850-166A0-GM	☆	☆	☆	☆	☆	☆	☆	☆	☆	3.0	.118	55	2.165	54.7	2.152	20	.803	0.3	.013
1.90	.075	17.1	.673	9	3	862.1-1900-171A0-GM	☆	☆	☆	☆	☆	☆	☆	☆	☆	3.0	.118	55	2.165	54.7	2.152	20	.823	0.3	.014
1.95	.077	17.6	.691	9	3	862.1-1950-175A0-GM	☆	☆	☆	☆	☆	☆	☆	☆	☆	3.0	.118	55	2.165	54.7	2.152	21	.846	0.4	.014
2.00	.079	18.0	.709	9	3	862.1-2000-180A0-GM	☆	☆	☆	☆	☆	☆	☆	☆	☆	3.0	.118	55	2.165	54.6	2.151	22	.866	0.4	.014
2.05	.081	18.5	.726	9	3	862.1-2050-184A0-GM	☆	☆	☆	☆	☆	☆	☆	☆	☆	3.0	.118	55	2.165	54.6	2.151	22	.890	0.4	.015
2.10	.083	18.9	.744	9	3	862.1-2100-189A0-GM	☆	☆	☆	☆	☆	☆	☆	☆	☆	3.0	.118	55	2.165	54.6	2.150	23	.909	0.4	.015
2.15	.085	19.4	.762	9	3	862.1-2150-193A0-GM	☆	☆	☆	☆	☆	☆	☆	☆	☆	3.0	.118	55	2.165	54.6	2.150	23	.933	0.4	.015
2.20	.087	19.8	.780	9	3	862.1-2200-198A0-GM	☆	☆	☆	☆	☆	☆	☆	☆	☆	3.0	.118	55	2.165	54.6	2.150	24	.953	0.4	.016
2.25	.089	20.3	.797	9	3	862.1-2250-202A0-GM	☆	☆	☆	☆	☆	☆	☆	☆	☆	3.0	.118	55	2.165	54.6	2.149	24	.976	0.4	.016
2.30	.091	20.7	.815	9	3	862.1-2300-207A0-GM	☆	☆	☆	☆	☆	☆	☆	☆	☆	3.0	.118	60	2.362	59.6	2.346	25	.996	0.4	.016
2.35	.093	21.2	.833	9	3	862.1-2350-211A0-GM	☆	☆	☆	☆	☆	☆	☆	☆	☆	3.0	.118	60	2.362	59.6	2.345	25	1.020	0.4	.017
2.40	.094	21.6	.850	9	3	862.1-2400-216A0-GM	☆	☆	☆	☆	☆	☆	☆	☆	☆	3.0	.118	60	2.362	59.6	2.345	26	1.039	0.4	.017
2.45	.096	22.1	.868	9	3	862.1-2450-220A0-GM	☆	☆	☆	☆	☆	☆	☆	☆	☆	3.0	.118	60	2.362	59.6	2.344	27	1.063	0.4	.018
2.50	.098	22.5	.886	9	3	862.1-2500-225A0-GM	☆	☆	☆	☆	☆	☆	☆	☆	☆	3.0	.118	60	2.362	59.6	2.344	27	1.083	0.5	.018
2.55	.100	23.0	.904	9	3	862.1-2550-229A0-GM	☆	☆	☆	☆	☆	☆	☆	☆	☆	3.0	.118	60	2.362	59.5	2.344	28	1.106	0.5	.018
2.60	.102	23.4	.921	9	3	862.1-2600-234A0-GM	☆	☆	☆	☆	☆	☆	☆	☆	☆	3.0	.118	60	2.362	59.5	2.344	28	1.126	0.5	.019
2.65	.104	23.9	.939	9	3	862.1-2650-238A0-GM	☆	☆	☆	☆	☆	☆	☆	☆	☆	3.0	.118	60	2.362	59.5	2.343	29	1.150	0.5	.019
2.70	.106	24.3	.957	9	3	862.1-2700-243A0-GM	☆	☆	☆	☆	☆	☆	☆	☆	☆	3.0	.118	60	2.362	59.5	2.343	29	1.169	0.5	.019
2.75	.108	24.8	.974	9	3	862.1-2750-247A0-GM	☆	☆	☆	☆	☆	☆	☆	☆	☆	3.0	.118	65	2.559	64.5	2.539	30	1.193	0.5	.020
2.80	.110	25.2	.992	9	3	862.1-2800-252A0-GM	☆	☆	☆	☆	☆	☆	☆	☆	☆	3.0	.118	65	2.559	64.5	2.539	30	1.213	0.5	.020
2.85	.112	25.7	1.010	9	3	862.1-2850-256A0-GM	☆	☆	☆	☆	☆	☆	☆	☆	☆	3.0	.118	65	2.559	64.5	2.539	31	1.236	0.5	.020
2.90	.114	26.1	1.028	9	3	862.1-2900-261A0-GM	☆	☆	☆	☆	☆	☆	☆	☆	☆	3.0	.118	65	2.559	64.5	2.538	31	1.256	0.5	.021
2.95	.116	26.6	1.045	9	3	862.1-2950-265A0-GM	☆	☆	☆	☆	☆	☆	☆	☆	☆	3.0	.118	65	2.559	64.5	2.538	32	1.280	0.5	.021
3.00	.118	27.0	1.063	9	3	862.1-3000-270A0-GM	☆	☆	☆	☆	☆	☆	☆	☆	☆	3.0	.118	65	2.559	64.5	2.537	33	1.299	0.5	.021



CoroDrill® 862-GM solid carbide micro drill

Internal coolant supply

8 - 16xD

TCHA JS7
SIG 137°

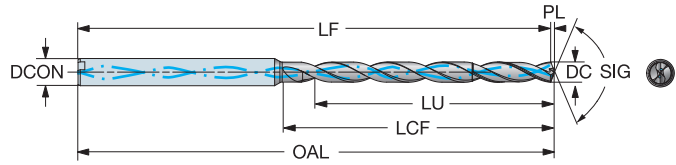

DC	DC*	LU	LU*	ULDR	CZC _{MS}	Ordering code	Dimensions, mm, inch																				
							P		M		K		N		S		H		O								
							X2BL	X2BM	X2BL	X2BM	X2BL	X2BM	X2BL	X2BM	X2BL	X2BM	X2BL	X2BM	X2BL	X2BM	DCON _{MS}	DCON _{MS} *	OAL	OAL*	LF	LF*	LCF
1.00	.039	9.0	.354	9	3	862.1-1000-090A1-GM	*	*	*	*	*	*	*	*	*	*	*	3.0	.118	51	2.008	50.8	2.001	11	.433	0.2	.007
1.00	.039	12.0	.472	12	3	862.1-1000-120A1-GM	*	*	*	*	*	*	*	*	*	*	3.0	.118	50	1.969	49.8	1.961	14	.551	0.2	.008	
1.00	.039	16.0	.630	16	3	862.1-1000-160A1-GM	*	*	*	*	*	*	*	*	*	*	3.0	.118	65	2.559	64.8	2.552	18	.709	0.2	.008	
1.10	.043	9.9	.390	9	3	862.1-1100-099A1-GM	*	*	*	*	*	*	*	*	*	*	3.0	.118	51	2.008	50.8	2.000	12	.472	0.2	.008	
1.10	.043	13.2	.520	12	3	862.1-1100-132A1-GM	*	*	*	*	*	*	*	*	*	*	3.0	.118	50	1.969	49.8	1.961	15	.610	0.2	.009	
1.10	.043	17.6	.693	16	3	862.1-1100-176A1-GM	*	*	*	*	*	*	*	*	*	*	3.0	.118	65	2.559	64.8	2.551	19	.768	0.2	.009	
1.20	.047	10.8	.425	9	3	862.1-1200-108A1-GM	*	*	*	*	*	*	*	*	*	*	3.0	.118	51	2.008	50.8	1.999	13	.512	0.2	.009	
1.20	.047	14.4	.567	12	3	862.1-1200-144A1-GM	*	*	*	*	*	*	*	*	*	*	3.0	.118	50	1.969	49.8	1.960	16	.650	0.2	.009	
1.20	.047	19.2	.756	16	3	862.1-1200-192A1-GM	*	*	*	*	*	*	*	*	*	*	3.0	.118	65	2.559	64.8	2.550	21	.827	0.2	.009	
1.30	.051	11.7	.461	9	3	862.1-1300-117A1-GM	*	*	*	*	*	*	*	*	*	*	3.0	.118	51	2.008	50.8	1.998	14	.551	0.2	.009	
1.30	.051	15.6	.614	12	3	862.1-1300-156A1-GM	*	*	*	*	*	*	*	*	*	*	3.0	.118	50	1.969	49.8	1.959	17	.689	0.3	.010	
1.30	.051	20.8	.819	16	3	862.1-1300-208A1-GM	*	*	*	*	*	*	*	*	*	*	3.0	.118	65	2.559	64.8	2.550	23	.906	0.3	.010	
1.40	.055	12.6	.496	9	3	862.1-1400-126A1-GM	*	*	*	*	*	*	*	*	*	*	3.0	.118	51	2.008	50.8	1.998	15	.591	0.3	.010	
1.40	.055	16.8	.661	12	3	862.1-1400-168A1-GM	*	*	*	*	*	*	*	*	*	*	3.0	.118	50	1.969	49.8	1.959	19	.748	0.3	.011	
1.40	.055	22.4	.882	16	3	862.1-1400-224A1-GM	*	*	*	*	*	*	*	*	*	*	3.0	.118	65	2.559	64.8	2.549	24	.965	0.3	.011	
1.50	.059	13.5	.531	9	3	862.1-1500-135A1-GM	*	*	*	*	*	*	*	*	*	*	3.0	.118	51	2.008	50.7	1.997	16	.650	0.3	.011	
1.50	.059	18.0	.709	12	3	862.1-1500-180A1-GM	*	*	*	*	*	*	*	*	*	*	3.0	.118	50	1.969	49.7	1.958	21	.827	0.3	.012	
1.50	.059	24.0	.945	16	3	862.1-1500-240A1-GM	*	*	*	*	*	*	*	*	*	*	3.0	.118	65	2.559	64.7	2.548	27	1.063	0.3	.012	
1.60	.063	14.4	.567	9	3	862.1-1600-144A1-GM	*	*	*	*	*	*	*	*	*	*	3.0	.118	51	2.008	50.7	1.996	17	.689	0.3	.011	
1.60	.063	19.2	.756	12	3	862.1-1600-192A1-GM	*	*	*	*	*	*	*	*	*	*	3.0	.118	50	1.969	49.7	1.957	22	.886	0.3	.012	
1.60	.063	25.6	1.008	16	3	862.1-1600-256A1-GM	*	*	*	*	*	*	*	*	*	*	3.0	.118	65	2.559	64.7	2.548	28	1.122	0.3	.012	
1.70	.067	15.3	.602	9	3	862.1-1700-153A1-GM	*	*	*	*	*	*	*	*	*	*	3.0	.118	51	2.008	50.7	1.996	18	.728	0.3	.012	
1.70	.067	20.4	.803	12	3	862.1-1700-204A1-GM	*	*	*	*	*	*	*	*	*	*	3.0	.118	50	1.969	49.7	1.956	23	.925	0.3	.013	
1.70	.067	27.2	1.071	16	3	862.1-1700-272A1-GM	*	*	*	*	*	*	*	*	*	*	3.0	.118	65	2.559	64.7	2.547	30	1.181	0.3	.013	
1.80	.071	16.2	.638	9	3	862.1-1800-162A1-GM	*	*	*	*	*	*	*	*	*	*	3.0	.118	51	2.008	50.7	1.995	19	.748	0.3	.013	
1.80	.071	21.6	.850	12	3	862.1-1800-216A1-GM	*	*	*	*	*	*	*	*	*	*	3.0	.118	50	1.969	49.7	1.956	24	.965	0.4	.014	
1.80	.071	28.8	1.134	16	3	862.1-1800-288A1-GM	*	*	*	*	*	*	*	*	*	*	3.0	.118	65	2.559	64.7	2.546	32	1.260	0.4	.014	
1.85	.073	16.2	.638	8	3	862.1-1850-162A1-GM	*	*	*	*	*	*	*	*	*	*	3.0	.118	51	2.008	50.7	1.994	19	.748	0.3	.013	
1.85	.073	21.6	.850	11	3	862.1-1850-216A1-GM	*	*	*	*	*	*	*	*	*	*	3.0	.118	55	2.165	54.7	2.152	24	.965	0.4	.014	
1.90	.075	17.1	.673	9	3	862.1-1900-171A1-GM	*	*	*	*	*	*	*	*	*	*	3.0	.118	51	2.008	50.7	1.994	20	.787	0.3	.014	
1.90	.075	22.8	.898	12	3	862.1-1900-228A1-GM	*	*	*	*	*	*	*	*	*	*	3.0	.118	55	2.165	54.7	2.152	26	1.024	0.4	.015	
1.90	.075	30.4	1.197	16	3	862.1-1900-304A1-GM	*	*	*	*	*	*	*	*	*	*	3.0	.118	65	2.559	64.7	2.545	33	1.319	0.4	.015	
1.98	.078	17.1	.673	8	3	862.1-1980-171A1-GM	*	*	*	*	*	*	*	*	*	*	3.0	.118	51	2.008	50.6	1.994	20	.787	0.4	.014	
1.98	.078	22.8	.898	11	3	862.1-1980-228A1-GM	*	*	*	*	*	*	*	*	*	*	3.0	.118	55	2.165	54.6	2.151	26	1.024	0.4	.015	
2.00	.079	18.0	.709	9	3	862.1-2000-180A1-GM	*	*	*	*	*	*	*	*	*	*	3.0	.118	51	2.008	50.6	1.994	21	.827	0.4	.014	
2.00	.079	24.0	.945	12	3	862.1-2000-240A1-GM	*	*	*	*	*	*	*	*	*	*	3.0	.118	55	2.165	54.6	2.151	27	1.063	0.4	.016	
2.00	.079	32.0	1.260	16	3	862.1-2000-320A1-GM	*	*	*	*	*	*	*	*	*	*	3.0	.118	65	2.559	64.6	2.545	35	1.378	0.4	.016	
2.05	.081	18.0	.709	8	3	862.1-2050-180A1-GM	*	*	*	*	*	*	*	*	*	*	3.0	.118	51	2.008	50.6	1.993	21	.827	0.4	.015	
2.05	.081	24.0	.945	11	3	862.1-2050-240A1-GM	*	*	*	*	*	*	*	*	*	*	3.0	.118	55	2.165	54.6	2.151	27	1.063	0.4	.016	
2.08	.082	18.0	.709	8	3	862.1-2080-180A1-GM	*	*	*	*	*	*	*	*	*	*	3.0	.118	51	2.008	50.6	1.993	21	.827	0.4	.015	
2.08	.082	24.0	.945	11	3	862.1-2080-240A1-GM	*	*	*	*	*	*	*	*	*	*	3.0	.118	55	2.165	54.6	2.150	27	1.063	0.4	.016	
2.10	.083	18.9	.744	9	3	862.1-2100-189A1-GM	*	*	*	*	*	*	*	*	*	*	3.0	.118	61	2.402	60.6	2.387	22	.866	0.4	.015	
2.10	.083	25.2	.992	12	3	862.1-2100-252A1-GM	*	*	*	*	*	*	*	*	*	*	3.0	.118	55	2.165	54.6	2.150	28	1.122	0.4	.016	
2.10	.083	33.6	1.323	16	3	862.1-2100-336A1-GM	*	*	*	*	*	*	*	*	*	*	3.0	.118	82	3.228	81.6	3.213	36	1.437	0.4	.016	
2.15	.085	18.9	.744	8	3	862.1-2150-189A1-GM	*	*	*	*	*	*	*	*	*	*	3.0	.118	61	2.402	60.6	2.386	22	.866	0.4	.015	
2.15	.085	25.2	.992	11	3	862.1-2150-252A1-GM	*	*	*	*	*	*	*	*	*	*	3.0	.118	55	2.165	54.6	2.150	28	1.122	0.4	.017	
2.18	.086	18.9	.744	8	3	862.1-2180-189A1-GM	*	*	*	*	*	*	*	*	*	*	3.0	.118	61	2.402	60.6	2.386	22	.866	0.4	.016	
2.18	.086	25.2	.992	11	3	862.1-2180-252A1-GM	*	*	*	*	*	*	*	*	*	*	3.0	.118	55	2.165	54.6	2.150	28	1.122	0.4	.017	
2.20	.087	19.8	.780	9	3	862.1-2200-198A1-GM	*	*	*	*	*	*	*	*	*	*	3.0	.118	61	2.402	60.6	2.386	23	.906	0.4	.016	
2.20	.087	26.4	1.039	12	3	862.1-2200-264A1-GM	*	*	*	*	*	*	*	*	*	*	3.0	.118	55	2.165	54.6	2.150	29	1.161	0.4	.017	



CoroDrill® 862-GM solid carbide micro drill

Internal coolant supply

8 - 16xD

TCHA JS7
SIG 137°

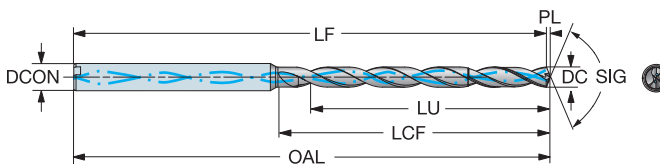

DC	DC*	LU	LU*	ULDR	CZC _{MS}	Ordering code	Material										Dimensions, mm, inch													
							P		M		K		N		S		H		O		DCON _{MS}	DCON _{MS} *	OAL	OAL*	LF	LF*	LCF	LCF*	PL	PL*
							X2BL	X2BM	X2BL	X2BM	X2BL	X2BM	X2BL	X2BM	X2BL	X2BM	X2BL	X2BM	X2BL	X2BM										
2.25	.089	19.8	.780	8	3	862.1-2250-198A1-GM	*	*	*	*	*	*	*	*	*	*	*	3.0	.118	61	2.402	60.6	2.385	23	.906	0.4	.016			
2.25	.089	26.4	1.039	11	3	862.1-2250-264A1-GM	*	*	*	*	*	*	*	*	*	*	*	3.0	.118	55	2.165	54.6	2.149	29	1.161	0.4	.017			
2.26	.089	19.8	.780	8	3	862.1-2260-198A1-GM	*	*	*	*	*	*	*	*	*	*	*	3.0	.118	61	2.402	60.6	2.385	23	.906	0.4	.016			
2.26	.089	26.4	1.039	11	3	862.1-2260-264A1-GM	*	*	*	*	*	*	*	*	*	*	*	3.0	.118	55	2.165	54.6	2.149	33	1.299	0.4	.018			
2.30	.091	20.7	.815	9	3	862.1-2300-207A1-GM	*	*	*	*	*	*	*	*	*	*	*	3.0	.118	61	2.402	60.6	2.385	24	.945	0.4	.016			
2.30	.091	27.6	1.087	12	3	862.1-2300-276A1-GM	*	*	*	*	*	*	*	*	*	*	*	3.0	.118	55	2.165	54.6	2.149	30	1.201	0.5	.018			
2.30	.091	36.8	1.449	16	3	862.1-2300-368A1-GM	*	*	*	*	*	*	*	*	*	*	*	3.0	.118	82	3.228	81.6	3.212	40	1.575	0.5	.018			
2.38	.094	20.7	.815	8	3	862.1-2380-207A1-GM	*	*	*	*	*	*	*	*	*	*	*	3.0	.118	61	2.402	60.6	2.385	24	.945	0.4	.017			
2.38	.094	27.6	1.087	11	3	862.1-2380-276A1-GM	*	*	*	*	*	*	*	*	*	*	*	3.0	.118	55	2.165	54.6	2.148	30	1.201	0.5	.018			
2.40	.094	21.6	.850	9	3	862.1-2400-216A1-GM	*	*	*	*	*	*	*	*	*	*	*	3.0	.118	61	2.402	60.6	2.384	24	.965	0.4	.017			
2.40	.094	28.8	1.134	12	3	862.1-2400-288A1-GM	*	*	*	*	*	*	*	*	*	*	*	3.0	.118	55	2.165	54.6	2.148	32	1.260	0.5	.019			
2.40	.094	38.4	1.512	16	3	862.1-2400-384A1-GM	*	*	*	*	*	*	*	*	*	*	*	3.0	.118	82	3.228	81.6	3.211	41	1.634	0.5	.019			
2.44	.096	21.6	.850	8	3	862.1-2440-216A1-GM	*	*	*	*	*	*	*	*	*	*	*	3.0	.118	61	2.402	60.6	2.384	24	.965	0.4	.017			
2.44	.096	28.8	1.134	11	3	862.1-2440-288A1-GM	*	*	*	*	*	*	*	*	*	*	*	3.0	.118	55	2.165	54.6	2.148	32	1.260	0.5	.019			
2.50	.098	22.5	.886	9	3	862.1-2500-225A1-GM	*	*	*	*	*	*	*	*	*	*	*	3.0	.118	61	2.402	60.6	2.384	25	1.004	0.5	.018			
2.50	.098	30.0	1.181	12	3	862.1-2500-300A1-GM	*	*	*	*	*	*	*	*	*	*	*	3.0	.118	60	2.362	59.6	2.344	33	1.299	0.5	.019			
2.50	.098	40.0	1.575	16	3	862.1-2500-400A1-GM	*	*	*	*	*	*	*	*	*	*	*	3.0	.118	82	3.228	81.6	3.211	43	1.693	0.5	.019			
2.58	.102	22.5	.886	8	3	862.1-2580-225A1-GM	*	*	*	*	*	*	*	*	*	*	*	3.0	.118	61	2.402	60.5	2.383	25	.984	0.5	.018			
2.58	.102	30.0	1.181	11	3	862.1-2580-300A1-GM	*	*	*	*	*	*	*	*	*	*	*	3.0	.118	60	2.362	59.5	2.343	33	1.299	0.5	.020			
2.60	.102	23.4	.921	9	3	862.1-2600-234A1-GM	*	*	*	*	*	*	*	*	*	*	*	3.0	.118	61	2.402	60.5	2.383	26	1.043	0.5	.019			
2.60	.102	31.2	1.228	12	3	862.1-2600-312A1-GM	*	*	*	*	*	*	*	*	*	*	*	3.0	.118	60	2.362	59.5	2.344	34	1.358	0.5	.020			
2.60	.102	41.6	1.638	16	3	862.1-2600-416A1-GM	*	*	*	*	*	*	*	*	*	*	*	3.0	.118	82	3.228	81.5	3.210	44	1.752	0.5	.020			
2.64	.104	23.4	.921	8	3	862.1-2640-234A1-GM	*	*	*	*	*	*	*	*	*	*	*	3.0	.118	61	2.402	60.5	2.383	26	1.043	0.5	.019			
2.64	.104	31.2	1.228	11	3	862.1-2640-312A1-GM	*	*	*	*	*	*	*	*	*	*	*	3.0	.118	60	2.362	59.5	2.343	34	1.358	0.5	.020			
2.70	.106	24.3	.957	9	3	862.1-2700-243A1-GM	*	*	*	*	*	*	*	*	*	*	*	3.0	.118	61	2.402	60.5	2.382	27	1.083	0.5	.019			
2.70	.106	32.4	1.276	12	3	862.1-2700-324A1-GM	*	*	*	*	*	*	*	*	*	*	*	3.0	.118	60	2.362	59.5	2.343	35	1.398	0.5	.021			
2.70	.106	43.2	1.701	16	3	862.1-2700-432A1-GM	*	*	*	*	*	*	*	*	*	*	*	3.0	.118	82	3.228	81.5	3.209	46	1.811	0.5	.021			
2.71	.107	24.3	.957	8	3	862.1-2710-243A1-GM	*	*	*	*	*	*	*	*	*	*	*	3.0	.118	61	2.402	60.5	2.382	27	1.083	0.5	.019			
2.71	.107	32.4	1.276	11	3	862.1-2710-324A1-GM	*	*	*	*	*	*	*	*	*	*	*	3.0	.118	60	2.362	59.5	2.343	35	1.398	0.5	.021			
2.80	.110	25.2	.992	9	3	862.1-2800-252A1-GM	*	*	*	*	*	*	*	*	*	*	*	3.0	.118	61	2.402	60.5	2.382	28	1.102	0.5	.020			
2.80	.110	33.6	1.323	12	3	862.1-2800-336A1-GM	*	*	*	*	*	*	*	*	*	*	*	3.0	.118	60	2.362	59.5	2.342	36	1.437	0.6	.022			
2.80	.110	44.8	1.764	16	3	862.1-2800-448A1-GM	*	*	*	*	*	*	*	*	*	*	*	3.0	.118	82	3.228	81.5	3.208	48	1.890	0.6	.022			
2.82	.111	25.2	.992	8	3	862.1-2820-252A1-GM	*	*	*	*	*	*	*	*	*	*	*	3.0	.118	61	2.402	60.5	2.382	28	1.102	0.5	.020			
2.82	.111	33.6	1.323	11	3	862.1-2820-336A1-GM	*	*	*	*	*	*	*	*	*	*	*	3.0	.118	60	2.362	59.5	2.342	36	1.437	0.6	.022			
2.87	.113	25.2	.992	8	3	862.1-2870-252A1-GM	*	*	*	*	*	*	*	*	*	*	*	3.0	.118	61	2.402	60.5	2.381	28	1.102	0.5	.021			
2.87	.113	33.6	1.323	11	3	862.1-2870-336A1-GM	*	*	*	*	*	*	*	*	*	*	*	3.0	.118	60	2.362	59.5	2.342	36	1.437	0.6	.022			
2.90	.114	26.1	1.028	9	3	862.1-2900-261A1-GM	*	*	*	*	*	*	*	*	*	*	*	3.0	.118	61	2.402	60.5	2.381	29	1.142	0.5	.021			
2.90	.114	34.8	1.370	12	3	862.1-2900-348A1-GM	*	*	*	*	*	*	*	*	*	*	*	3.0	.118	60	2.362	59.5	2.341	38	1.496	0.6	.022			
2.90	.114	46.4	1.827	16	3	862.1-2900-464A1-GM	*	*	*	*	*	*	*	*	*	*	*	3.0	.118	82	3.228	81.5	3.207	49	1.949	0.6	.022			
2.95	.116	26.1	1.028	8	3	862.1-2950-261A1-GM	*	*	*	*	*	*	*	*	*	*	*	3.0	.118	61	2.402	60.5	2.380	29	1.142	0.5	.021			
2.95	.116	34.8	1.370	11	3	862.1-2950-348A1-GM	*	*	*	*	*	*	*	*	*	*	*	3.0	.118	60	2.362	59.5	2.341	38	1.496	0.6	.023			
3.00	.118	27.0	1.063	9	3	862.1-3000-270A1-GM	*	*	*	*	*	*	*	*	*	*	*	3.0	.118	61	2.402	60.5	2.380	31	1.220	0.5	.021			
3.00	.118	36.0	1.417	12	3	862.1-3000-360A1-GM	*	*	*	*	*	*	*	*	*	*	*	3.0	.118	60	2.362	59.5	2.341	40	1.575	0.6	.023			
3.00	.118	48.0	1.890	16	3	862.1-3000-480A1-GM	*	*	*	*	*	*	*	*	*	*	*	3.0	.118	82	3.228	81.5	3.207	52	2.047	0.6	.023			



86



89

CoroDrill® 862-GM solid carbide micro drill

Micro PCD drill

External coolant supply

TCHA H7
SIG 118°

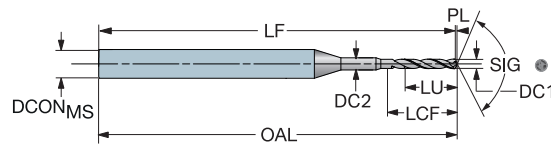
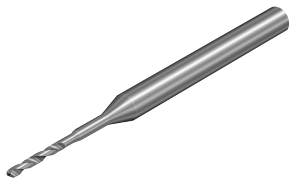

											N		S		O		Dimensions, mm, inch										
											X	I	X	I	X	I											
DC ₁	DC ₁ [*]	DC ₂	DC ₂ [*]	LU	LU [*]	CZC _{MS}	Ordering code				DCON _{MS}	DCON _{MS} [*]	OAL	OAL [*]	LF	LF [*]	LCF	LCF [*]	PL	PL [*]							
0.300	.0118	1.270	.0500	1.5	.059	3	862.3-0300-015A0-GM	*	*	*	3.0	.118	37	1.476	37.4	1.473	2.0	.080	0.1	.004							
0.300	.0118	1.270	.0500	2.4	.094	3	862.3-0300-024A0-GM	*	*	*	3.0	.118	37	1.476	37.4	1.473	2.9	.115	0.1	.004							
0.300	.0118	1.270	.0500	3.6	.142	3	862.3-0300-036A0-GM	*	*	*	3.0	.118	37	1.476	37.4	1.473	4.1	.162	0.1	.004							
0.397	.0156	1.270	.0500	2.0	.079	3	862.3-0397-019A0-GM	*	*	*	3.0	.118	37	1.476	37.4	1.472	2.7	.106	0.1	.005							
0.397	.0156	1.270	.0500	3.2	.126	3	862.3-0397-031A0-GM	*	*	*	3.0	.118	37	1.476	37.4	1.472	3.9	.154	0.1	.005							
0.397	.0156	1.270	.0500	4.8	.189	3	862.3-0397-047A0-GM	*	*	*	3.0	.118	37	1.476	37.4	1.472	5.4	.213	0.1	.005							
0.400	.0157	1.270	.0500	2.0	.079	3	862.3-0400-020A0-GM	*	*	*	3.0	.118	37	1.476	37.4	1.472	2.6	.106	0.1	.005							
0.400	.0157	1.270	.0500	3.2	.126	3	862.3-0400-032A0-GM	*	*	*	3.0	.118	37	1.476	37.4	1.472	3.8	.153	0.1	.005							
0.400	.0157	1.270	.0500	4.8	.189	3	862.3-0400-048A0-GM	*	*	*	3.0	.118	37	1.476	37.4	1.472	5.4	.216	0.1	.005							
0.500	.0197	1.270	.0500	2.5	.098	3	862.3-0500-025A0-GM	*	*	*	3.0	.118	37	1.476	37.4	1.470	3.3	.133	0.2	.006							
0.500	.0197	1.270	.0500	4.0	.157	3	862.3-0500-040A0-GM	*	*	*	3.0	.118	37	1.476	37.4	1.470	4.8	.192	0.2	.006							
0.500	.0197	1.270	.0500	6.0	.236	3	862.3-0500-060A0-GM	*	*	*	3.0	.118	37	1.476	37.4	1.470	6.8	.270	0.2	.006							
0.600	.0236	1.270	.0500	3.0	.118	3	862.3-0600-030A0-GM	*	*	*	3.0	.118	37	1.476	37.3	1.469	4.0	.159	0.2	.007							
0.600	.0236	1.270	.0500	4.8	.189	3	862.3-0600-048A0-GM	*	*	*	3.0	.118	37	1.476	37.3	1.469	5.8	.230	0.2	.007							
0.600	.0236	1.270	.0500	7.2	.283	3	862.3-0600-072A0-GM	*	*	*	3.0	.118	37	1.476	37.3	1.469	8.2	.324	0.2	.007							
0.700	.0276	1.270	.0500	3.5	.138	3	862.3-0700-035A0-GM	*	*	*	3.0	.118	37	1.476	37.3	1.468	4.7	.185	0.2	.008							
0.700	.0276	1.270	.0500	5.6	.220	3	862.3-0700-056A0-GM	*	*	*	3.0	.118	37	1.476	37.3	1.468	6.8	.268	0.2	.008							
0.700	.0276	1.270	.0500	8.4	.331	3	862.3-0700-084A0-GM	*	*	*	3.0	.118	37	1.476	37.3	1.468	9.6	.378	0.2	.008							
0.794	.0313	1.270	.0500	4.0	.157	3	862.3-0794-039A0-GM	*	*	*	3.0	.118	37	1.476	37.3	1.467	5.3	.209	0.2	.009							
0.794	.0313	1.270	.0500	6.4	.252	3	862.3-0794-063A0-GM	*	*	*	3.0	.118	37	1.476	37.3	1.467	7.7	.303	0.2	.009							
0.800	.0315	1.270	.0500	4.0	.157	3	862.3-0800-040A0-GM	*	*	*	3.0	.118	37	1.476	37.3	1.467	5.3	.212	0.2	.009							
0.800	.0315	1.270	.0500	6.4	.252	3	862.3-0800-064A0-GM	*	*	*	3.0	.118	37	1.476	37.3	1.467	7.7	.307	0.2	.009							
0.900	.0354	1.270	.0500	4.5	.177	3	862.3-0900-045A0-GM	*	*	*	3.0	.118	37	1.476	37.2	1.466	6.0	.239	0.3	.011							
0.900	.0354	1.270	.0500	7.2	.283	3	862.3-0900-072A0-GM	*	*	*	3.0	.118	37	1.476	37.2	1.466	8.7	.345	0.3	.011							
1.000	.0394	1.270	.0500	5.0	.197	3	862.3-1000-050A0-GM	*	*	*	3.0	.118	37	1.476	37.2	1.465	6.7	.265	0.3	.012							
1.000	.0394	1.270	.0500	8.0	.315	3	862.3-1000-080A0-GM	*	*	*	3.0	.118	37	1.476	37.2	1.465	9.7	.383	0.3	.012							
1.100	.0433	1.270	.0500	5.5	.217	3	862.3-1100-055A0-GM	*	*	*	3.0	.118	37	1.476	37.2	1.463	7.4	.292	0.3	.013							
1.100	.0433	1.270	.0500	8.8	.346	3	862.3-1100-088A0-GM	*	*	*	3.0	.118	37	1.476	37.2	1.463	10.7	.422	0.3	.013							
1.200	.0472	1.270	.0500	6.0	.236	3	862.3-1200-060A0-GM	*	*	*	3.0	.118	37	1.476	37.1	1.462	8.0	.318	0.4	.014							
1.200	.0472	1.270	.0500	9.6	.378	3	862.3-1200-096A0-GM	*	*	*	3.0	.118	37	1.476	37.1	1.462	11.6	.460	0.4	.014							

B

C

D

E

CoroDrill® 862-GM solid carbide micro drill

Micro PCD drill

External coolant supply (5 - 12xD)

TCHA H7
SIG 118°

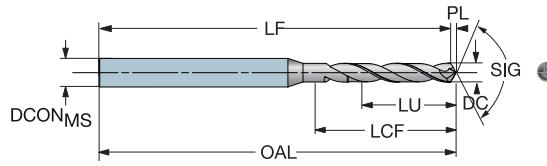
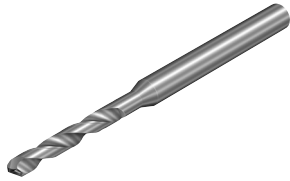

DC	DC*	LU	LU*	ULDR	CZC _{MS}	Ordering code	N S O			Dimensions, mm, inch									
							X1DU	X1DU	X1DU	DCON _{MS}	DCON _{MS} *	OAL	OAL*	LF	LF*	LCF	LCF*	PL	PL*
1.300	.051	6.5	.256	5	3	862.1-1300-065A0-GM	*	*	*	3.0	.118	37	1.476	37.1	1.461	8.7	.344	0.4	.015
1.300	.051	10.4	.409	8	3	862.1-1300-104A0-GM	*	*	*	3.0	.118	37	1.476	37.1	1.461	12.6	.498	0.4	.015
1.300	.051	15.6	.614	12	3	862.1-1300-156A0-GM	*	*	*	3.0	.118	37	1.476	37.1	1.461	17.8	.703	0.4	.015
1.400	.055	7.0	.276	5	3	862.1-1400-070A0-GM	*	*	*	3.0	.118	37	1.476	37.1	1.460	9.4	.371	0.4	.017
1.400	.055	11.2	.441	8	3	862.1-1400-112A0-GM	*	*	*	3.0	.118	37	1.476	37.1	1.460	13.6	.536	0.4	.017
1.400	.055	16.8	.661	12	3	862.1-1400-168A0-GM	*	*	*	3.0	.118	50	1.969	49.6	1.952	19.2	.757	0.4	.017
1.500	.059	7.5	.295	5	3	862.1-1500-075A0-GM	*	*	*	3.0	.118	37	1.476	37.0	1.459	10.1	.398	0.5	.018
1.500	.059	12.0	.472	8	3	862.1-1500-120A0-GM	*	*	*	3.0	.118	37	1.476	37.0	1.459	14.6	.575	0.5	.018
1.500	.059	18.0	.709	12	3	862.1-1500-180A0-GM	*	*	*	3.0	.118	50	1.969	49.5	1.951	20.6	.811	0.5	.018
1.588	.063	7.9	.313	5	3	862.1-1588-079A0-GM	*	*	*	3.0	.118	37	1.476	37.0	1.458	10.6	.421	0.5	.019
1.588	.063	12.7	.500	7	3	862.1-1588-127A0-GM	*	*	*	3.0	.118	37	1.476	37.0	1.458	15.4	.608	0.5	.019
1.588	.063	19.1	.750	11	3	862.1-1588-190A0-GM	*	*	*	3.0	.118	50	1.969	49.5	1.950	21.8	.859	0.5	.019
1.600	.063	8.0	.315	5	3	862.1-1600-080A0-GM	*	*	*	3.0	.118	37	1.476	37.0	1.457	10.7	.424	0.5	.019
1.600	.063	12.8	.504	8	3	862.1-1600-128A0-GM	*	*	*	3.0	.118	37	1.476	37.0	1.457	15.5	.613	0.5	.019
1.600	.063	19.2	.756	12	3	862.1-1600-192A0-GM	*	*	*	3.0	.118	50	1.969	49.5	1.950	21.9	.865	0.5	.019
1.700	.067	8.5	.335	5	3	862.1-1700-085A0-GM	*	*	*	3.0	.118	37	1.476	37.0	1.456	11.4	.450	0.5	.020
1.700	.067	13.6	.535	8	3	862.1-1700-136A0-GM	*	*	*	3.0	.118	37	1.476	37.0	1.456	16.5	.651	0.5	.020
1.700	.067	20.4	.803	12	3	862.1-1700-204A0-GM	*	*	*	3.0	.118	50	1.969	49.5	1.948	23.3	.919	0.5	.020
1.800	.071	9.0	.354	5	3	862.1-1800-090A0-GM	*	*	*	3.0	.118	37	1.476	37.0	1.455	12.1	.477	0.5	.021
1.800	.071	14.4	.567	8	3	862.1-1800-144A0-GM	*	*	*	3.0	.118	37	1.476	37.0	1.455	17.5	.690	0.5	.021
1.800	.071	21.6	.850	12	3	862.1-1800-216A0-GM	*	*	*	3.0	.118	50	1.969	49.5	1.947	24.7	.973	0.5	.021
1.900	.075	9.5	.374	5	3	862.1-1900-095A0-GM	*	*	*	3.0	.118	37	1.476	36.9	1.454	12.7	.504	0.6	.022
1.900	.075	15.2	.598	8	3	862.1-1900-152A0-GM	*	*	*	3.0	.118	50	1.969	49.4	1.946	18.4	.728	0.6	.022
1.900	.075	22.8	.898	12	3	862.1-1900-228A0-GM	*	*	*	3.0	.118	50	1.969	49.4	1.946	26.0	1.027	0.6	.022
1.984	.078	9.9	.391	5	3	862.1-1984-099A0-GM	*	*	*	3.0	.118	37	1.476	36.9	1.453	13.3	.526	0.6	.023
1.984	.078	15.9	.625	7	3	862.1-1984-158A0-GM	*	*	*	3.0	.118	50	1.969	49.4	1.945	19.3	.760	0.6	.023
1.984	.078	23.8	.937	11	3	862.1-1984-238A0-GM	*	*	*	3.0	.118	50	1.969	49.4	1.945	27.2	1.072	0.6	.023
2.000	.079	10.0	.394	5	3	862.1-2000-100A0-GM	*	*	*	3.0	.118	37	1.476	36.9	1.453	13.4	.530	0.6	.024
2.000	.079	16.0	.630	8	3	862.1-2000-160A0-GM	*	*	*	3.0	.118	50	1.969	49.4	1.945	19.4	.766	0.6	.024
2.000	.079	24.0	.945	12	3	862.1-2000-240A0-GM	*	*	*	3.0	.118	50	1.969	49.4	1.945	27.4	1.081	0.6	.024
2.100	.083	10.5	.413	5	3	862.1-2100-105A0-GM	*	*	*	3.0	.118	37	1.476	36.9	1.452	14.1	.557	0.6	.025
2.100	.083	16.8	.661	8	3	862.1-2100-168A0-GM	*	*	*	3.0	.118	50	1.969	49.4	1.944	20.4	.805	0.6	.025
2.100	.083	25.2	.992	12	3	862.1-2100-252A0-GM	*	*	*	3.0	.118	50	1.969	49.4	1.944	28.8	1.135	0.6	.025
2.200	.087	11.0	.433	5	3	862.1-2200-110A0-GM	*	*	*	3.0	.118	37	1.476	36.8	1.450	14.8	.583	0.7	.026
2.200	.087	17.6	.693	8	3	862.1-2200-176A0-GM	*	*	*	3.0	.118	50	1.969	49.3	1.942	21.4	.843	0.7	.026
2.200	.087	26.4	1.039	12	3	862.1-2200-264A0-GM	*	*	*	3.0	.118	50	1.969	49.3	1.942	30.2	1.189	0.7	.026
2.300	.091	11.5	.453	5	3	862.1-2300-115A0-GM	*	*	*	3.0	.118	37	1.476	36.8	1.449	15.4	.609	0.7	.027
2.300	.091	18.4	.724	8	3	862.1-2300-184A0-GM	*	*	*	3.0	.118	50	1.969	49.3	1.941	22.3	.881	0.7	.027
2.300	.091	27.6	1.087	12	3	862.1-2300-276A0-GM	*	*	*	3.0	.118	62	2.461	61.8	2.433	31.5	1.243	0.7	.027
2.381	.094	11.9	.469	4	3	862.1-2381-119A0-GM	*	*	*	3.0	.118	37	1.476	36.8	1.448	16.0	.631	0.7	.028
2.381	.094	19.0	.750	7	3	862.1-2381-190A0-GM	*	*	*	3.0	.118	50	1.969	49.3	1.940	23.1	.912	0.7	.028
2.381	.094	28.6	1.125	11	3	862.1-2381-285A0-GM	*	*	*	3.0	.118	62	2.461	61.8	2.432	32.7	1.287	0.7	.028
2.400	.094	12.0	.472	5	3	862.1-2400-120A0-GM	*	*	*	3.0	.118	37	1.476	36.8	1.448	16.1	.636	0.7	.028
2.400	.094	19.2	.756	8	3	862.1-2400-192A0-GM	*	*	*	3.0	.118	50	1.969	49.3	1.940	23.3	.920	0.7	.028
2.400	.094	22.8	.898	9	3	862.1-2400-288A0-GM	*	*	*	3.0	.118	62	2.461	61.8	2.432	32.9	1.298	0.7	.028
2.500	.098	12.5	.492	5	3	862.1-2500-125A0-GM	*	*	*	3.0	.118	37	1.476	36.7	1.447	16.8	.663	0.8	.030
2.500	.098	20.0	.787	8	3	862.1-2500-200A0-GM	*	*	*	3.0	.118	50	1.969	49.2	1.939	24.3	.958	0.8	.030
2.500	.098	30.0	1.181	12	3	862.1-2500-300A0-GM	*	*	*	3.0	.118	62	2.461	61.7	2.431	34.3	1.352	0.8	.030
2.600	.102	13.0	.512	5	3	862.1-2600-130A0-GM	*	*	*	3.0	.118	37	1.476	36.7	1.446	17.5	.689	0.8	.031
2.600	.102	20.8	.819	8	3	862.1-2600-208A0-GM	*	*	*	3.0	.118	50	1.969	49.2	1.938	25.3	.996	0.8	.031
2.600	.102	31.2	1.228	12	3	862.1-2600-312A0-GM	*	*	*	3.0	.118	62	2.461	61.7	2.430	35.7	1.406	0.8	.031



CoroDrill® 862-GM solid carbide micro drill

Micro PCD drill

External coolant supply (5 - 12xD)

TCHA H7
SIG 118°

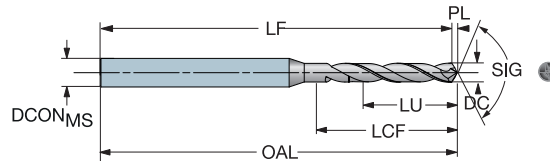
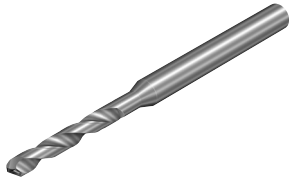

										N S O			Dimensions, mm, inch									
										X1DU	X1DU	X1DU	DCON _{MS}	DCON _{MS} ^a	OAL	OAL ^a	LF	LF ^a	LCF	LCF ^a	PL	PL ^a
DC	DC ^a	LU	LU ^a	ULDR	CZG _{MS}	Ordering code																
2.700	.106	13.5	.531	5	3	862.1-2700-135A0-GM	*	*	*	3.0	.118	37	1.476	36.7	1.444	18.1	.716	0.8	.032			
2.700	.106	21.6	.850	8	3	862.1-2700-216A0-GM	*	*	*	3.0	.118	50	1.969	49.2	1.937	26.2	1.035	0.8	.032			
2.700	.106	32.4	1.276	12	3	862.1-2700-324A0-GM	*	*	*	3.0	.118	62	2.461	61.7	2.429	37.0	1.460	0.8	.032			
2.778	.109	13.9	.547	5	3	862.1-2778-138A0-GM	*	*	*	3.0	.118	50	1.969	49.2	1.936	18.7	.736	0.8	.033			
2.778	.109	22.2	.875	7	3	862.1-2778-222A0-GM	*	*	*	3.0	.118	50	1.969	49.2	1.936	27.0	1.065	0.8	.033			
2.778	.109	33.3	1.312	11	3	862.1-2778-333A0-GM	*	*	*	3.0	.118	62	2.461	61.7	2.428	38.1	1.502	0.8	.033			
2.800	.110	14.0	.551	5	3	862.1-2800-140A0-GM	*	*	*	3.0	.118	50	1.969	49.2	1.935	18.8	.742	0.8	.033			
2.800	.110	22.4	.882	8	3	862.1-2800-224A0-GM	*	*	*	3.0	.118	50	1.969	49.2	1.935	27.2	1.073	0.8	.033			
2.800	.110	33.6	1.323	12	3	862.1-2800-336A0-GM	*	*	*	3.0	.118	62	2.461	61.7	2.428	38.4	1.514	0.8	.033			
2.900	.114	14.5	.571	5	3	862.1-2900-145A0-GM	*	*	*	3.0	.118	50	1.969	49.1	1.934	19.5	.769	0.9	.034			
2.900	.114	23.2	.913	8	3	862.1-2900-232A0-GM	*	*	*	3.0	.118	50	1.969	49.1	1.934	28.2	1.111	0.9	.034			
2.900	.114	34.8	1.370	12	3	862.1-2900-348A0-GM	*	*	*	3.0	.118	62	2.461	61.6	2.426	39.8	1.568	0.9	.034			
3.000	.118	15.0	.591	5	3	862.1-3000-150A0-GM	*	*	*	3.0	.118	50	1.969	49.1	1.933	20.2	.795	0.9	.035			
3.000	.118	24.0	.945	8	3	862.1-3000-240A0-GM	*	*	*	3.0	.118	50	1.969	49.1	1.933	29.2	1.150	0.9	.035			
3.000	.118	36.0	1.417	12	3	862.1-3000-360A0-GM	*	*	*	3.0	.118	62	2.461	61.6	2.425	41.2	1.622	0.9	.035			



CoroDrill® 862-GM solid carbide micro drill for pilot holes

Pilot drill for micro holes

External coolant supply

TCHA H8
SIG 140°

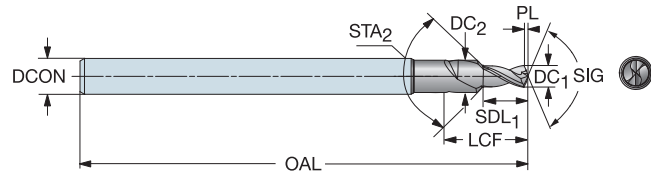
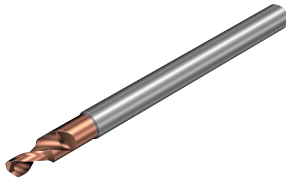

DC ₁	DC ₁ *	DC ₂	DC ₂ *	STA	LU	LU*	CZC _{MS}	Ordering code	Dimensions, mm, inch																	
									P	M	K	N	S	H	O	DCON _{MS}	DCON _{MS} *	OAL	OAL*	LF	LF*	LCF	LCF*	PL	PL*	
2.58	.102	3.44	.135	90°	5.0	.197	4	862.2-2580-050A0-GP	★	★	★	★	★	★	★	★	4.0	.157	50	1.969	49.3	1.939	12	.500	0.5	.018
2.60	.102	3.47	.137	90°	5.2	.205	4	862.2-2600-052A0-GP	★	★	★	★	★	★	★	★	4.0	.157	50	1.969	49.3	1.939	12	.500	0.5	.019
2.64	.104	3.50	.138	90°	5.2	.205	4	862.2-2640-052A0-GP	★	★	★	★	★	★	★	★	4.0	.157	50	1.969	49.2	1.939	12	.500	0.5	.019
2.65	.104	3.53	.139	90°	5.2	.205	4	862.2-2650-052A0-GP	★	★	★	★	★	★	★	★	4.0	.157	50	1.969	49.2	1.939	12	.500	0.5	.019
2.70	.106	3.60	.142	90°	5.4	.213	4	862.2-2700-054A0-GP	★	★	★	★	★	★	★	★	4.0	.157	50	1.969	49.2	1.938	13	.531	0.5	.019
2.71	.107	3.61	.142	90°	5.4	.213	4	862.2-2710-054A0-GP	★	★	★	★	★	★	★	★	4.0	.157	50	1.969	49.2	1.938	13	.531	0.5	.019
2.75	.108	3.67	.144	90°	5.4	.213	4	862.2-2750-054A0-GP	★	★	★	★	★	★	★	★	4.0	.157	50	1.969	49.2	1.937	13	.531	0.5	.020
2.80	.110	3.73	.147	90°	5.6	.220	4	862.2-2800-056A0-GP	★	★	★	★	★	★	★	★	4.0	.157	50	1.969	49.2	1.937	13	.531	0.5	.020
2.82	.111	3.76	.148	90°	5.6	.220	4	862.2-2820-056A0-GP	★	★	★	★	★	★	★	★	4.0	.157	50	1.969	49.2	1.937	13	.531	0.5	.020
2.85	.112	3.80	.150	90°	5.6	.220	4	862.2-2850-056A0-GP	★	★	★	★	★	★	★	★	4.0	.157	50	1.969	49.2	1.936	13	.531	0.5	.020
2.87	.113	3.83	.151	90°	5.6	.220	4	862.2-2870-056A0-GP	★	★	★	★	★	★	★	★	4.0	.157	50	1.969	49.2	1.936	13	.531	0.5	.021
2.90	.114	3.87	.152	90°	5.8	.228	4	862.2-2900-058A0-GP	★	★	★	★	★	★	★	★	4.0	.157	50	1.969	49.2	1.935	14	.551	0.5	.021
2.95	.116	3.93	.155	90°	5.9	.232	4	862.2-2950-059A0-GP	★	★	★	★	★	★	★	★	4.0	.157	50	1.969	49.2	1.935	14	.551	0.5	.021
3.00	.118	4.00	.157	90°	6.0	.236	4	862.2-3000-060A0-GP	★	★	★	★	★	★	★	★	4.0	.157	50	1.969	49.1	1.934	14	.551	0.5	.021



Tool holding

ENG

Blade carrier for Y-axis parting blades 80

B

C

D

E



86

Blade carrier for Y-axis parting blades

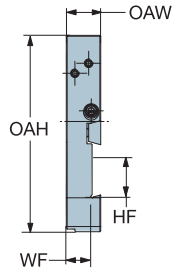
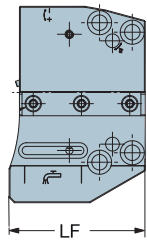

					Dimensions, mm							
CZC _{MS}	CZC _{MS}	CNSC	CXSC	Ordering code	LF	WF	HF	OAW	OAH	(BAR)	(NM)	(KG)
30	25L	1	2	APBL-25Y-BC	79.0	20.0	25.0	20.0	114.0	80	10	1.0
	25R	1	2	APBR-25Y-BC	79.0	20.0	25.0	20.0	114.0	80	10	1.0

For APBR/L tool holders when performing Y-axis parting

Rotating tool adaptors

Coromant Capto® to MDI adaptor
HSK to MDI adaptor

83
84

Coromant Capto® to MDI adaptor

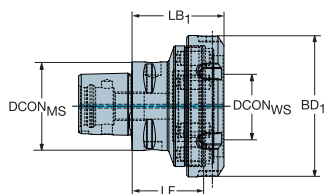

					Dimensions, mm								
CZC _{MS}	CZC _{WS}	CNSC	CXSC	Ordering code	DCON _{MS}	DCON _{WS}	LF	LB ₁	BD ₁	BAR	NM	KG	RPMX
C6	MDI-50	3	1	C6-DM50-N-043	63.0	50.0	43.0	57.0	94.7	80	250.00	1.70	20000
C8	MDI-50	3	1	C8-DM50-N-040	80.0	50.0	40.0	54.0	94.7	80	250.00	2.28	14000

For spare parts, visit www.sandvik.coromant.com



A

HSK to MDI adaptor

Machine side interface HSK A/C/T

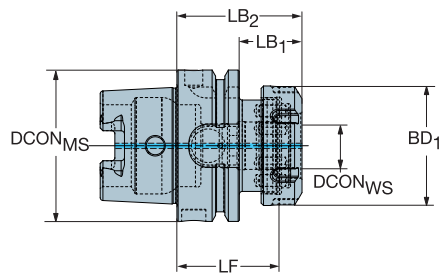
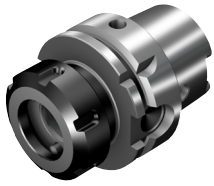

B

Dimensions, mm

CZC _{MS}	CZC _{WS}	CNSC	CXSC	Ordering code	DCON _{MS}	DCON _{WS}	LF	LB ₁	LB ₂	BD ₁	BAR	NM	KG	RPMX
100	MDI-50	1	1	HT10-DM50-N-055	100.0	50.0	55.0	40.0	69.0	94.7	80	250.00	3.15	12500

For spare parts, visit www.sandvik.coromant.com

C

D

E



86

General information

ISO 13399	86
Coolant supply information	89
Safety information	90
Coromant Recycling Concept (CRC)	91

ISO 13399 is an international standard that strives to simplify the exchange of data for cutting tools. You will notice a slight difference through the new parameters and descriptions of each tool.

For the first time ever, there is a standardized way of describing product data regarding cutting tools. When all tools in the industry share the same parameters and definitions, communicating tool information becomes very straightforward.

What does this mean to you?



Basically, it means that your systems can talk to ours, as they all speak the same language. Download product data from our web site and use it directly in your CAD/CAM software to assemble tools that you use in production. No need to look for information in catalogues and interpret data from one system to another. Imagine how much time this will save you!

Short name	Preferred Name
ADJLN	Minimum adjustment limit
ADJLX	Maximum adjustment limit
ADJRG	Adjustment range
ALP	Clearance angle axial
AN	Clearance angle major
ANN	Clearance angle minor
APMX	Depth of cut maximum
APMX_EFW	Depth of cut maximum - end feed
APMX_FFW	Depth of cut maximum - side feed
AZ	Maximum plunge depth
B	Shank width
BAWS	Body angle workpiece side
BAMS	Body angle machine side
BBD	Balanced by design
BBR	Balanced by rotational test
BCH	Corner chamfer length
BD	Body diameter
BHTA	Body half taper angle
BN	Face land width
BS	Wiper edge length
BSG	Basic standard group
BSR	Wiper edge radius
CBMD	Chip breaker manufacturer
CDX	Cutting depth maximum
CEMR	Cutting edge major radius
CF	Spot chamfer
CHBA	Chamfer body angle
CHBL	Chamfer body length
CHW	Corner chamfer width
CICT	Cutting item count
CICT _{BALL}	Cutting item count - Ball nose insert
CICT _E	Cutting item count - end position
CICT _P	Cutting item count - peripheral position
CICT _S	Cutting item count - side position
CICT _{SP}	Cutting item count - Shank protection insert
CICT _T	Cutting item count - total
CND	Coolant entry diameter
CNSC	Coolant entry style code
CNT	Coolant entry thread size
COATING	Coating
CP	Max coolant pressure
CRKS	Connection retention knob thread size
CRNT	Coolant radial entry thread size
CTPT	Operation type
CUTDIA	Work piece parting diameter maximum
CW	Cutting width
CWN	Minimum cutting width
CWTOLL	Cutting width lower tolerance
CWTOLU	Cutting width upper tolerance
CWX	Cutting width maximum
CXSC	Coolant exit style code
CZC	Connection size code
CZC _{MS}	Connection size code machine side
CZC _{WS}	Connection size code workpiece side
D1	Fixing hole diameter
DAH	Diameter access hole
DAXIN	Axial groove inside diameter minimum
DAXN	Minimum axial groove outside diameter

DAXX	Axial groove outside diameter maximum
DBC	Diameter bolt circle
DC	Cutting diameter
DCB	Connection bore diameter
DCBN	Connection bore diameter minimum
DCBX	Connection bore diameter maximum
DCF	Cutting diameter face contact
DCIN	Cutting diameter internal
DCN	Cutting diameter minimum
DCON	Connection diameter
DCON _{MS}	Connection diameter machine side
DCON _{WS}	Connection diameter workpiece side
DCONN _{WS}	Connection diameter minimum workpiece side
DCONX _{WS}	Connection diameter maximum workpiece side
DCPS	Data chip provision size
DCSF _{MS}	Contact surface diameter machine side
DCSF _{WS}	Contact surface diameter workpiece side
DCX	Cutting diameter maximum
DHUB	Hub diameter
DIX	Tool changer interference diameter maximum
DMIN	Minimum bore diameter
DMM	Shank diameter
DN	Neck diameter
DRVCT	Drive count
DSGN	Design
EPSR	Insert included angle
FHA	Flute helix angle
FLGT	Flange thickness
FTDZ	For thread diameter size
GB	Face land angle
H	Shank height
HA	Thread height theoretical
HB	Thread height difference
HBH	Head bottom offset height
HC	Thread height actual
HF	Functional height
HRY	Lowest point from reference plain
HSUP	Support height
HTB	Body height
HTH	Height
IC	Inscribed circle diameter
INSL	Insert length
INSUC	Insert usage code
IZC	Insert size code
KAPR	Tool cutting edge angle
KAPR_EFW	Tool cutting edge angle - end feed
KCH	Corner chamfer
KRINS	Major cutting edge angle
KWW	Keyway width
L	Cutting edge length
LAMS	Inclination angle
LB	Body length
LCF	Length chip flute
LCOX	Cut off length maximum
LE	Cutting edge effective length
LF	Functional length
LFN	Minimum functional length
LH	Head length
LPR	Protruding length
LS	Shank length
LSC	Clamping length
LSCN	Clamping length minimum
LSCS	Distance to clamping start
LSCX	Clamping length maximum
LSD	Dead shank length
LU	Usable length (max. recommended)
LU_BFW	Usable length - back facing
LUX	Usable length maximum
MHD	Mounting hole distance
MIID	Master insert identification
MIID _E	Master insert identification - end position
MIID _S	Master insert identification - side position
MIID _C	Master insert identification - central position
MIID _P	Master insert identification - peripheral position
MIID _I	Master insert identification - intermediate position
MMCC	Code for preset torque
MMCX	Max. cutting torque
NOF	Flute count
NT	Tooth count
OAH	Overall height
OAL	Overall length
OAW	Overall width
OH	Overhang recommended
OHN	Overhang minimum

OHX	Overhang maximum
ORDCODE	Ordercode
PCL	Peripheral cylindrical length
PDX	Profile distance ex
PDY	Profile distance ey
PHD	Premachined hole diameter
PHDX	Maximum premachined hole diameter
PL	Point length
PNA	Profile included angle
PRFRAD	Profile radius
PRSPC	Profile specification
PSIR	Tool lead angle
PSIRL	Cutting edge angle major left hand
PSIRR	Cutting edge angle major right hand
PSW	Premachined slot width
RADH	Radial body height
RADW	Radial body width
RAR	Right hand relief angle
RE	Corner radius
REEQ	Corner radius equivalent
REL	Corner radius left
RER	Corner radius right
RETOLL	Corner radius lower tolerance
RETOLU	Corner radius upper tolerance
RGL	Regrind length
RMPX	Maximum ramping angle
RPMX	Rotational speed maximum
S	Insert thickness
SDL	Step diameter length
SIG	Point angle
SPTL	Splitline
SSC	Insert seat size code
SSC _E	Insert seat size code - end position
SSC _P	Insert seat size code - peripheral position
SSC _S	Insert seat size code - side position
STA	Step included angle
STDNO	Standard number
SUBSTRATE	Substrate
TCDC	Tolerance class cutting diameter
TCDCON	Connection diameter tolerance
TCDDMM	Shank diameter tolerance
TCHA	Achievable hole tolerance
TCHAL	Achievable hole tolerance lower
TCHAU	Achievable hole tolerance upper
TCT	Tolerance class tool
TCTR	Thread tolerance class
TD	Thread diameter
TDZ	Thread diameter size
TFLA	Tap floating length ahead
TFLB	Tap floating length behind
TG	Taper gradient
THBTP	Thread back taper property
THCA	Thread helix correction angle
THCHT	Threading chamfer type
THFT	Form type
THFTS	Thread form standard series
THL	Thread length
THUB	Hub thickness
TP	Thread pitch
TPI	Threads per inch
TPIN	Threads per inch minimum
TPIX	Threads per inch maximum
TPN	Thread pitch minimum
TPT	Thread profile type
TPX	Maximum thread pitch
TRMAX	Tap range max
TQ	Torque
TSYC	Tool style code
TTP	Thread type
ULDR	Usable length diameter ratio
VCX	Maximum cutting speed
W1	Insert width
WB	Body width
WF	Functional width
WFCIRP	Width to cutting item reference point
WSC	Clamping width
WT	Weight of item
ZADJ	Insert adjustable count
ZEFF	Face effective cutting edge count
ZEFP	Peripheral effective cutting edge count (ZEFP)
ZWX	Maximum number of Wiper inserts

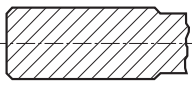
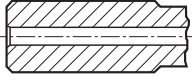
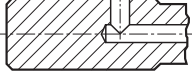
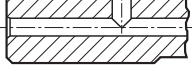
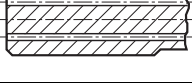
CNSC**Coolant entry style code**

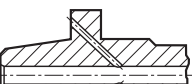
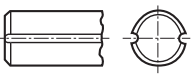
Code	Description	Image
0	Without coolant	
1	Axial concentric entry	
2	Radial entry	
3	Axial concentric and radial entry	
4	Axial concentric entry on circle	
5	Radial entry before adaptor	
6	Decentral over flange	
7	Decentral over flange and axial	
8	Decentral over slots on the shank	

CXSC**Coolant exit style code**

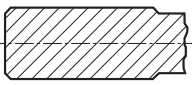
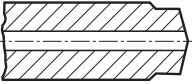
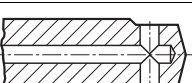
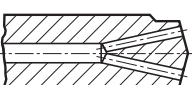
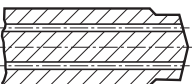
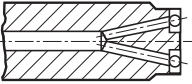
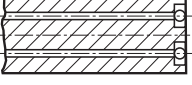
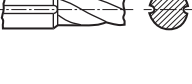
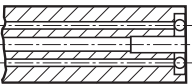
Code	Description	Image
0	No coolant exit	
1	Axial concentric exit	
2	Radial exit	
3	Axial inclined exit	
4	Axial concentric on circle	
5	Axial inclined exit with nozzle, adjustable	
6	Decentral exit with nozzle, adjustable	
7	Decentral over slots on the shank	
8	Axial or decentral with nozzle, adjustable	

Safety information in connection with grinding of cemented carbide

Material composition

Most metal products contain tungsten carbide and cobalt. Other substances that may be present in hard metal are titanium carbide, tantalum carbide, niobium carbide, chromium carbide, molybdenum carbide or vanadium carbide. Some grades contain titanium carbonitride and/or nickel.

Routes of exposure

Grinding or heating of hard metal blanks or hard metal products will produce products that give off dangerous dust and fumes. Avoiding ingestion and contact with skin or eyes is very important.

Acute toxicity

Intake of the aforementioned substances is toxic. Inhalation may cause irritation and inflammation of the airways. Significantly higher acute inhalation toxicity has been reported during simultaneous inhalation of cobalt and tungsten carbide compared to inhalation of cobalt alone.

Skin contact can cause irritation and rash. Sensitive individuals may even experience an allergic reaction.

Chronic toxicity

Repeated inhalation of aerosols containing cobalt may cause obstruction of the airways. Prolonged exposure to increased concentrations may cause lung fibrosis or lung cancer. Epidemiological studies indicate that workers previously exposed to high concentrations of tungsten carbide/cobalt carried an increased risk of developing lung cancer.

Cobalt and nickel are potent skin sensitizers. Repeated or prolonged contact can cause irritation and sensitization.

Risk phrases

Toxic: danger of serious damage to health by prolonged exposure through inhalation

Toxic when inhaled

Limited evidence of a carcinogenic effect.

May cause sensitization by inhalation and skin contact

Preventive measures

Avoid formation and inhalation of dust. Use adequate local exhaust ventilation to keep personal exposure well below nationally authorised limits.

If ventilation is not available or adequate, use respirators appropriately approved for the purpose.

Use safety goggles or glasses with side shields when necessary.

Avoid repeated skin contact. Wear suitable gloves. Wash skin thoroughly after handling.

Use suitable protective clothing. Launder clothing if needed.

Do not eat, drink or smoke in the working area. Wash skin thoroughly before eating, drinking or smoking.



For the sake of the environment

Get into the Sandvik Coromant Recycling Concept (CRC) now!

The Sandvik Coromant Recycling Concept (CRC) is a comprehensive service for used carbide inserts and solid carbide tools offered by Sandvik Coromant to all its customers.

In the light of increasing consumption of non-renewable raw materials, the economic management of dwindling resources is a duty owed by all manufacturers.

Sandvik Coromant is playing its part by offering to collect used carbide inserts and solid carbide tools and recycle them in the most environmentally friendly way.

All used carbide inserts are collected in the collection box at the workplace.

When the collection box is sufficiently full, its contents are transferred to the transport box.

The full transport box is then sent to the nearest Sandvik Coromant office or to your Sandvik Coromant dealer who can also give you more information.

The benefits of the CRC speak for themselves

- A worldwide ISO and OHAS certified recycling system.
- Open to all Sandvik Coromant customers.
- Simple procedure with collection and transport boxes.
- Less waste, easing the burden on the environment.
- Better utilisation of resources.
- Other manufacturers' carbide inserts are also accepted.

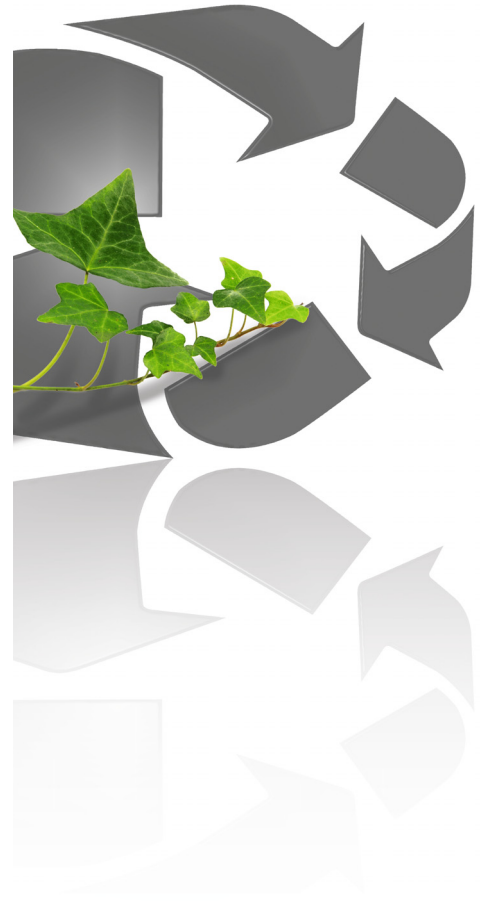

B

C

D

Order collection boxes for each lathe, milling machine, drill or for your machining centre. We recommend one collection box for inserts and one separate box for solid carbide tools for each cutting workplace.

For detailed instructions on how to sell your used cemented carbide, please visit www.sandvik.coromant.com and select your market.

Collection box:	Order numbers
Transport box for solid carbide tools (plywood):	91617
Transport box inserts (plywood):	92994
	92995

E